



SUBMITTAL DOCUMENT

Client :

Strathcona Regional District
990 Cedar Street
Campbell River, BC V9W 7Z8
Tel. 250-830-6700

Date : December 20th, 2024

Project Number : 214023

Project Name : **Strathcona Rec Complex**

Location : Campbell River, BC

Contact : **EI Solutions Inc.**

Consultant :

Polar Engineering
722 Cormorant Street #300
Victoria, BC V8W 4A5
Tel. 778-700-1086

Jonathan Ruccolo
4621 Louis B. Mayer
Laval, Québec
Tel. 514-920-0021

COPIES: Electronic	Submitted for: Approval		Acknowledgement
--------------------	-------------------------	---	-----------------

EI Solutions Desiccant Dehumidifier:

- Product Model A35G (16 000 CFM)

Product Description:

- Double wall extruded aluminum cabinet construction with 1.5" expanded polystyrene foam
- Rain louver module for outside air intake
- 1940mm x 400mm desiccant wheel c/w motorized bypass damper
- 1100MBH direct-fired natural gas reactivation heater
- End supply air and Side C return air duct connections
- AC type direct-drive supply fan blower array c/w VFDs
- AC type direct-drive reactivation fan blower c/w VFD
- Modulating return air and outside air dampers
- Pleated MERV-8 process pre-filters c/w pressure transducer
- Empty section for future field installed post cooling coil complete with aluminum drain pan
- 575V/3Ph/60Hz single point power connection with NEMA 3R non-fused disconnect switch
- ALC microprocessor with BACnet MS/TP communication
- NEMA-4 electrical controls panel with integral HMI
- 120V convenience outlet on independent circuit (field installation and power by others)
- Reactivation air inlet temperature sensor
- Space mount Temperature/RH combo sensor (field installation by others)

Unit Physical & Electrical Characteristics			
Overall Dimensions	Weight	FLA/MCA	Recommended Fuse Size
306" L x 148" W x 130" H	11,050 lbs. +/- 10%	41.4 / 44.5	50A



EI Solutions inc.

EI Solutions inc.
Strathcona Gardens Rec Complex RBAA
A – Series (A35G)
Desiccant Dehumidifier
Technical Submittal
24-1202

El Solutions Inc.

4621 Louis B. Mayer, Laval, Québec, H7P 6G5, Canada

Phone: (514) 920-0021

Version 0.2 - El Solutions 24-1202 – December 20, 2024

Approval Return Sheet

Engineer / Contractor Submittal Review

- Reviewed and Approved
- Approved as noted, see attached comments.
- Revise and resubmit, see attached comments.

By: _____

Date: _____

Revisions

Version 0.1: Initial Release	– 2024-12-19
Version 0.2: Revised Gas Capacity	– 2024-12-20

1. Unit Summary Description

Merv 8 Supply Air Filters

1100 MBH Natural Gas Direct Fired Reactivation Heater

Desiccant Rotor

AC Centrifugal Backward Curved Supply Fan Array

Flat-Blade Backward Inclined Centrifugal Reactivation Fan

Post Cooling Coil Section Includes Aluminum Drain Pan Only

Insulated, Opposed Blade Aluminum Outdoor, Return, & Bypass Air Damper with Modulating Belimo Actuators

ALC Microprocessor Controller with Integral HMI

NEMA-4 Electrical Controls Panel

Mixed, Supply & Outdoor Air Temperature and Humidity Sensors

Reactivation Inlet Air NTC Type II Temperature Sensor

Reactivation Outlet Air NTC Type II Temperature Sensor

Reactivation Rotor Inlet RTD Sensor with Transmitter

Convenience Outlet (Wired by others, separate feed)

Temperature & Humidity Wall Mount Sensor (Shipped Loose)

2. Contacts

Jonathan Ruccolo
514-920-0021 ext. 204
jonathan.ruccolo@eisolutions.ca

3. Table of Contents

Contents

1. Unit Summary Description.....	3
2. Contacts	4
3. Table of Contents.....	5
4. Equipment Schedule	7
5. Airflow Schematic	10
6. Unit Drawings.....	11
7. General Engineering Data for A-Series Desiccant.....	15
a) General	15
b) Cabinet	15
c) Base	15
d) Filters	16
e) Fans	16
f) Dampers & Louvers.....	16
g) Control	16
h) Electrical	17
i) Desiccant Rotor Dehumidifier.....	17
j) Direct-Fired Reactivation Burner	17
l) Installation Consideration & Minimum Requirements	18
8. Gas-Fired Desiccant Ice Rink Application Unit Control Sequence.....	19
9. Roof Curb Details	25
10. Rigging Details	26
11. Component Details	27
a) Wall Panel Data Sheet	27
b) Damper Data Sheet	29
c) Filter – Merv 8 Data Sheet.....	32
d) Supply Fan Data Sheet	34
e) Reactivation Fan Data Sheet	36
f) Desiccant Wheel Motor Data Sheet.....	38
g) Desiccant Wheel 2D Drawing	39
h) Direct Heater Data Sheet.....	40
i) Direct Heater 2D Drawing	41
j) ALC Microprocessor Controller Data Sheet	42

k) Direct Fired Heater Modules Link 44

4. Equipment Schedule

DATA SHEET	A35G
-------------------	-------------

DESCRIPTION
Desiccant Dehumidifier

AIR FLOW		
Supply Air Flow	16,000	CFM
Outside Air Flow	0 - 16,000	CFM
External Static Pressure	1.00	INCH WC.
Future Cooling Coil Pressure	0.75	INCH WC.
Total Static Pressure	6.05	INCH WC.

UNIT DIMENSIONS		
Base Frame Length	288	INCHES
Base Frame Width	116	INCHES
Base Frame Height	6	INCHES
Overall Length	306	INCHES
Overall Width	148.03	INCHES
Overall Height	130	INCHES
Estimated Weight (Dry)	11,050	LBS (+/-10%)
Construction	Extruded Aluminum & 1-1/2" Polyurethane Foam	

ELECTRICAL REQUIREMENTS		
Supply Voltage	575 / 3 / 60	V / PH / Hz
FLA	41.4	A
MCA	44.5	A
MOP	57.0	A
Power	41.2	kW
Recommended Fuse Size	50	A

CONNECTIONS	
Return Air Connection	28" x 78"
Supply Air Connection	48" x 34"
Gas Connection	1 " Ø

AIR FILTERS	
Process Air Filters	2" Pleated MERV 8
Filter Size	16" x 20" x 2"
Filter Quantity	18

SUPPLY FAN	
Type	AC Centrifugal Backward Curved Fan
Manufacturer	Ziehl-Abegg
Quantity	3 Pcs
Air Flow	5,333 CFM Each
Supply Voltage	460 VAC
Input Power	7.32 kW
Current Draw	12.5 Amps
Power Factor	1.0
Speed	2,450 RPM

REACTIVATION FAN	
Type	Flat Blade Backward Inclined Centrifugal Fan, Direct Drive
Quantity	1
CFM	4,500 CFM
Voltage	575 VAC
Current Draw	8.1 AMPS
Power	10.0 HP
Power Factor	0.89 PF
Speed	3600 RPM
External Static Pressure	1.55 INCH WC.
Total Static Pressure	5.23 INCH WC.

DESICCANT WHEEL	
Size	1940 mm
Thickness	400 mm
Motor Power	0.12 kW
Supply Pressure Drop	2.50 INCH W.C.
React. Pressure Drop	2.51 INCH W.C.
Moisture Removal	497.14 LBS/HR

REACTIVATION HEATER	
Type	Direct Fired Burner, Nat. Gas
Quantity	1
Capacity	1100 MBH
Air Pressure Drop	0.68 IN W.C.
Gas Pressure	7 to 14 IN W.C
Turndown Ratio	26:1
Electrical Rating	115V/6A

5. Airflow Schematic

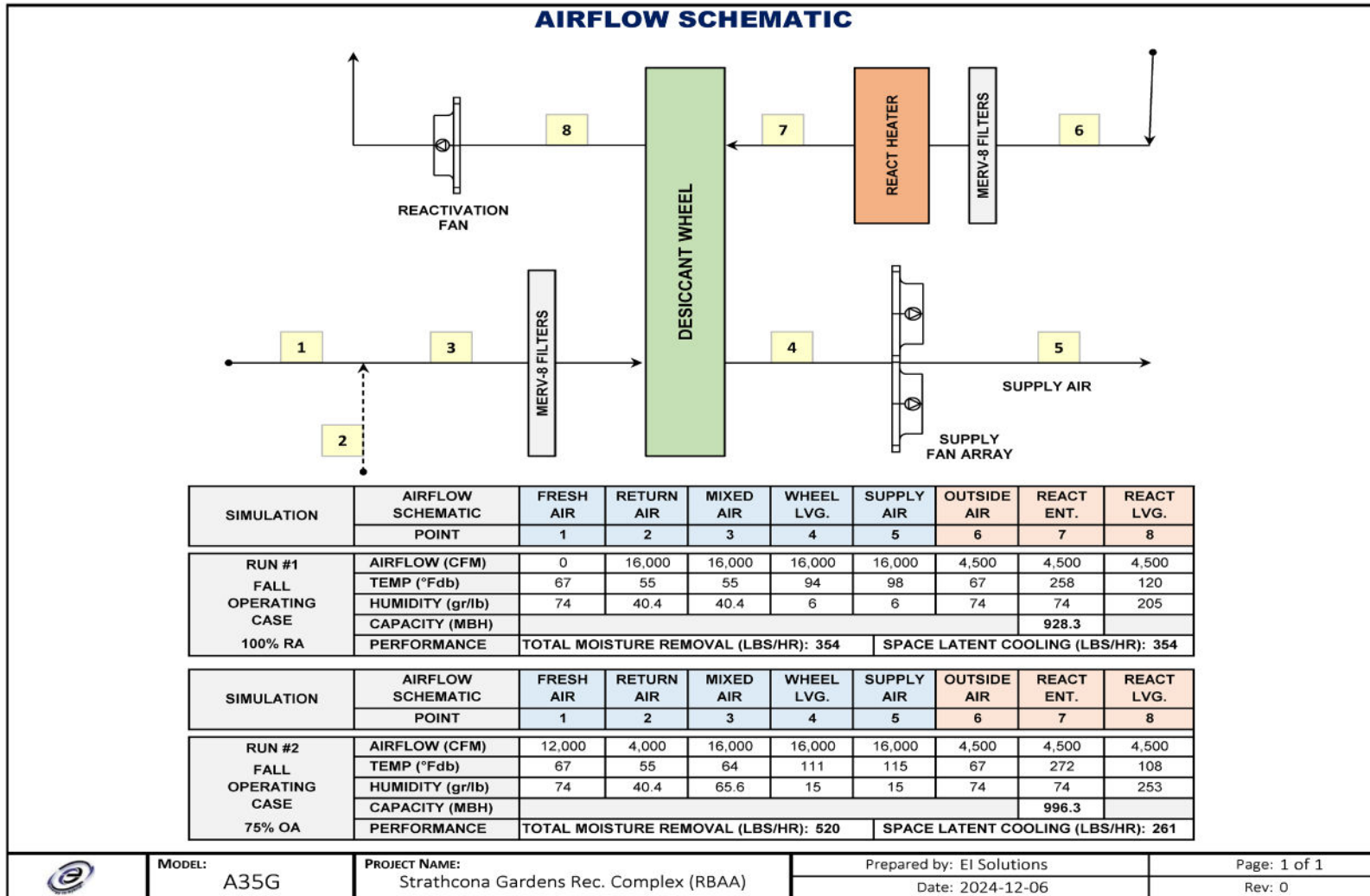

6. Unit Drawings

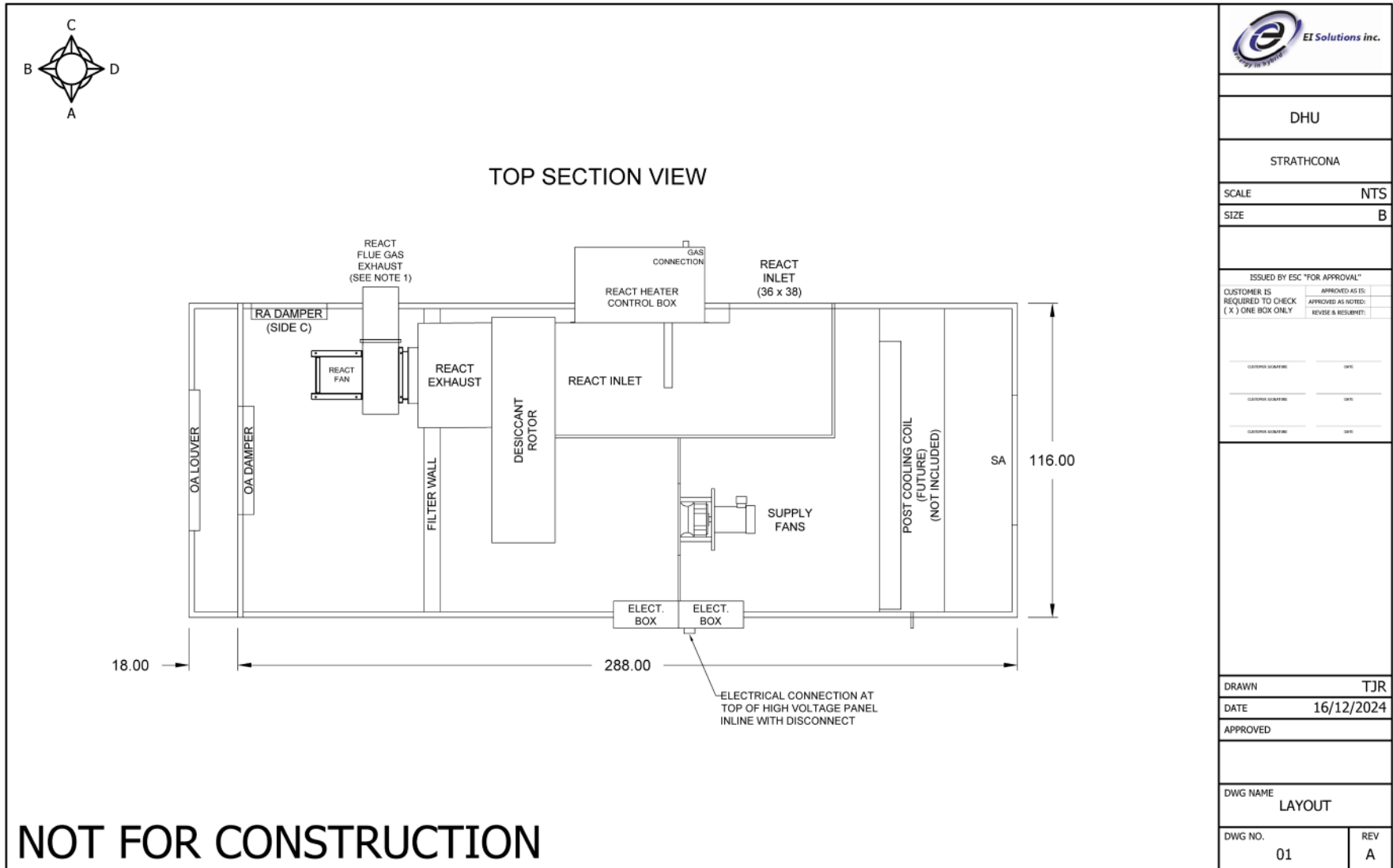

NOT FOR CONSTRUCTION

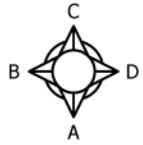

SIDE A SECTION VIEW

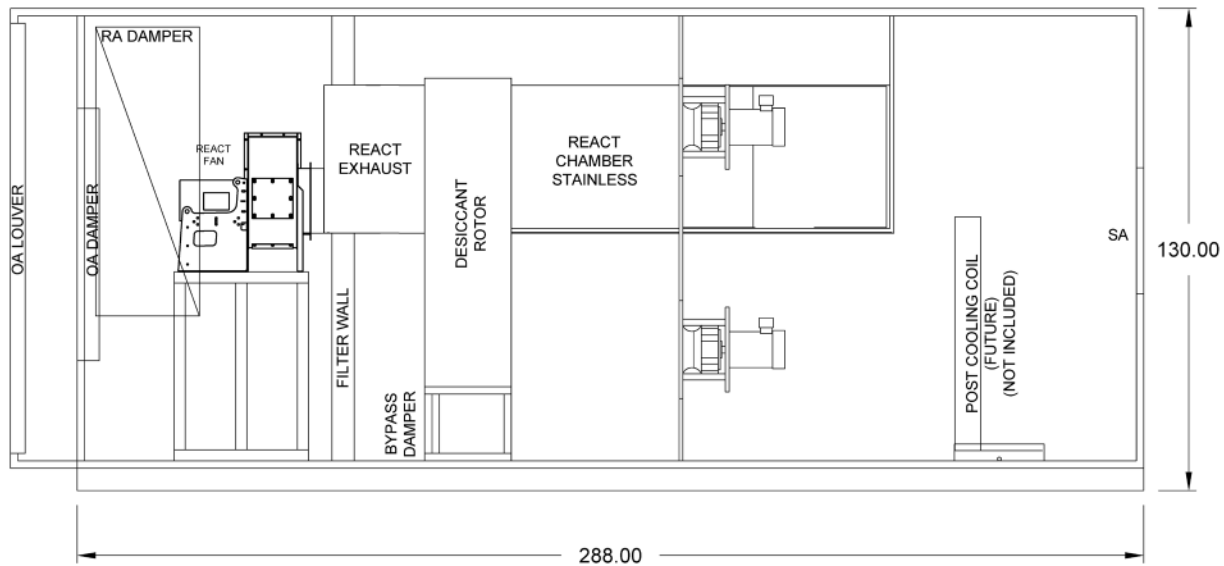

NOT FOR CONSTRUCTION



DHU

STRATHCONA

SCALE NTS

SIZE B

ISSUED BY ESC "FOR APPROVAL"

CUSTOMER IS REQUIRED TO CHECK (X) ONE BOX ONLY	APPROVED AS IS: APPROVED AS NOTED: REVISE & RESUBMIT:
<input type="checkbox"/>	<input type="checkbox"/>
<input type="checkbox"/>	<input type="checkbox"/>

CUSTOMER SIGNATURE: DATE:

CUSTOMER SIGNATURE: DATE:

CUSTOMER SIGNATURE: DATE:

DRAWN TJR

DATE 16/12/2024

APPROVED

DWG NAME LAYOUT

DWG NO. 02	REV A
------------	-------

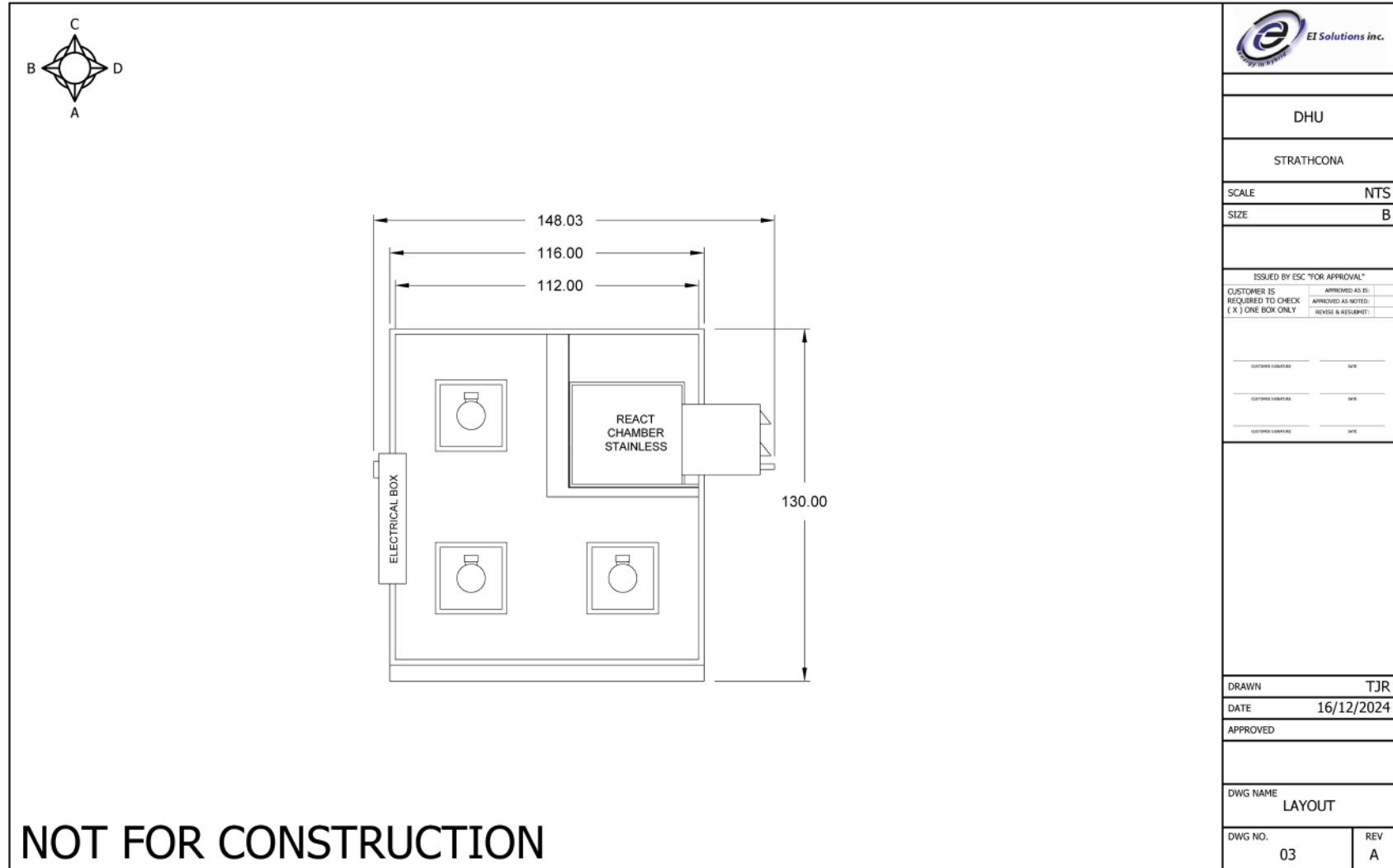

NOT FOR CONSTRUCTION



DHU	
STRATHCONA	
SCALE	NTS
SIZE	B

ISSUED BY ESC "FOR APPROVAL"	
CUSTOMER IS REQUIRED TO CHECK (X) ONE BOX ONLY	APPROVED AS NOTED: REVERSE & RESUBMIT:
<input type="checkbox"/>	<input type="checkbox"/>
<input type="checkbox"/>	<input type="checkbox"/>
<input type="checkbox"/>	<input type="checkbox"/>

DRAWN	TJR
DATE	16/12/2024
APPROVED	

DWG NAME LAYOUT	
DWG NO. 03	REV A

7. General Engineering Data for A-Series Desiccant

a) General

Air handler (AHU) manufacturer, registered under ISO 9001- 2015. Guaranteed to meet performance specification. Units are available for indoor or outdoor and designed for year-round operation.

Virtual or on-site start-up required to meet warranty requirements. Turn-key AHU units are sent to site pre-assembled, and factory tested. They will include all components required to control humidity levels, independent of fluctuating load conditions, within design limits.

The connection of utilities, ductwork, remote sensors and/or controllers by others. Space humidity set point is self-regulated by staged control of the honeycomb dehumidification rotor's metal silicate substrate. Reactivation heat source shall be in the form of a modulating direct-fired gas burner, steam or electric; automatically cycling off during low humidity conditions to minimize energy consumption.

b) Cabinet

AHUs are fabricated with high strength 6063 T5 Light Weight Aluminum extrusions, with a white powder coat finish and exceptional corrosion resistivity. The structural integrity is of light weight insulated composite panels composed of an insulated foam core laminated between two sheets of powder coated white aluminum. The doors are also made with the same using foam core insulated composite panels with high pressure rubber gasket seals.

All of the Aluminum is purchased with a minimum 60% recycled content (48% Pre-Consumer Content & 12% Post Consumer Content) with recovered raw materials that are received from regional suppliers. All excess drop materials that naturally occur in the manufacturing process are recycled locally. This should allow for LEED credits. All major joints and the perimeter are caulked with non-silicone caulking. Outdoor AHU roofs shall be built with rain guards and an EPDM rubber membrane. Temperature and pressure testing ports are located on the outside of the unit. AHU door hinges have a pressure relief mechanism for added safety.

c) Base

AHU structural bases are constructed in house of continuously welded heavy gauge (0.188) Extruded Aluminum tubing - Made here in Canada – provided for the base perimeter, reinforcing ribs, and all joints. The base is further constructed with Integrated balanced lifting points for ease of installation.

d) Filters**Pre-Filters**

The AHU pre-filters are MERV 8, which provide 30% filtration. Filters comply with ASHRAE standard 52.2. Filter racks are arranged for ease of servicing. Filter pressure differential switches are standard, with optional differential pressure transducers available at extra cost.

e) Fans

The unit shall be equipped with supply, reactivation, and optional condenser fans to provide the scheduled airflows as indicated. Supply fans shall be direct drive, backward curved, single intake AC centrifugal fans. Reactivation fan shall be a single width, single inlet, direct drive, designed with either a cast aluminum backward curved wheel or cast aluminum radial bladed wheel. In optional air-cooled condenser add-on, condenser fan shall be an EC axial fan featuring a guard grill.

f) Dampers & Louvers

The dampers are built with extruded aluminum, utilizing opposed blade design for even distribution of airflow; including low pressure drop and leakage rating in accordance with AMCA Standard 500-D-98. All dampers are of insulated damper blade type.

The drainable stormproof louvers are available and will have a depth of 4", made with extruded aluminum and with a galvanized bird screen.

g) Control

Equipped with industry leading HVAC control components and sensors resulting in accurate control. Refer to standard sequence of operation for more control details. Site or application specific controls and interface can be provided as necessary. If you prefer to have a partnered control system provider's equipment inside the AHU, please contact us for more information.

Human Machine Interfaces (HMIs) in the AHU and additional remote HMIs can be provided as an option, allowing maintenance staff to have quick and intuitive access of the information and alerts. The sensor suite includes air volume measurement of the supply fan, temperature, and dewpoint readings for humidity monitoring of the room and supply conditions. Filter switches included monitor loading; optional filter transducer can be selected. Internal data transfer uses serial Modbus communications to pass copious amounts of data between the controller and its peripherals. The controller can communicate with third party devices over Modbus RTU and TCP, or BACnet MSTP and IP, to access AHU data.

(For a list of available sensors, refer to the manufacturers' manuals)

h) Electrical

The AHU has a non-fused, main power disconnect, mounted to the high voltage panel, and engaged by an operating mechanism on the panel cover. The unit shall be equipped with thermal overload protection. The entire unit is factory wired in accordance with Canadian Electrical Code. The unit is ESA certified prior to shipping. A single high voltage power connection shall be required for all units. All electrical panel and peripheral devices are suitable for indoor or outdoor application, as per site requirement.

i) Desiccant Rotor Dehumidifier

The unit shall be equipped with a desiccant rotor and cassette. Ideal for optimum humidity control, where efficient dehumidifying is critical with an operating range of 0 to 100% relative humidity. Made of metal silicate synthesized in-situ glass fiber substrate, as the desiccant/adsorbent. The net organic compounds in the honeycomb media shall not exceed 2%. Benefits include water washable, incombustible, high mechanical strength in honeycomb matrix to endure stressful thermal cycling, no-acid constructed matrix (pH neutral), stainless steel construction of rim with integral rolled flange resulting in high corrosion resistance and increased longevity in moisture rich environments. The energy efficient design eliminates matrix burn-off/sintering. The rotors and cassettes are UL certified and produced in ISO 14001:2004 (Environmental Management System Standard) and ISO 9001:2008 (Quality Management System Standard) certified facility.

j) Direct-Fired Reactivation Burner

The AHU is equipped with a direct fired (DF) gas burner. Meeting ANSI Z83.4/ CSA 3.7 standard, for "Non-Recirculating Direct Gas-Fired Heating and Forced Ventilation Appliances for Commercial and Industrial Application". The DF reactivation burner will be in accordance with the National Fuel Gas Code ANSI Z223.1 (NFPA 54) in the United States and Can/CGA-B149 installation Code in Canada. The reactivation module shall provide 100% efficiency of combustion, minimum thermal efficiency of 92%, stainless-steel burner with aluminum burner head casting. The heat module shall employ, gas burners, with integral carryovers, improved turndown ratio with modulating controls, burner circulating air pressure switch to prove air supply for combustion and operation, flame safeguard of gas burner with integral flame sensing, burner ignition via intermittent pilot, listed gas valves (electric safety shut off valve, etc.), automatic reset type high limit switch, Class II step down transformer, test gauge in the gas train, union fitting to facilitate installation and service.

I) Installation Consideration & Minimum Requirements

AHU is recommended to be 6" off a concrete pad or floor. Units elevated more than 2 ft off the ground from bottom of the base rail would be ideal to have a permanent work platform with fixed ladder access.

Minimum one meter away from all sides. Ducts must be seal and insulated. All clearances for combustion equipment must follow local jurisdiction. Electrical and gas must be installed as per local jurisdictional codes and standards. All trades must adhere to local jurisdictional codes and laws.

8. Gas-Fired Desiccant Ice Rink Application Unit Control Sequence

SECTION 1: SYSTEM OVERVIEW

The EI Solutions A-Series units are designed to provide an efficient way to control space conditions within an ice rink. The typical space temperatures in ice arenas range between 55°F (12.8°C) to 65°F (18.3°C). Consequently, to provide first-rate ice quality and mitigate any moisture related issues such as fogging and condensation, the humidity level in the space must be maintained between 36°F (2.2°C) to 42°F (5.5°C) dew point.

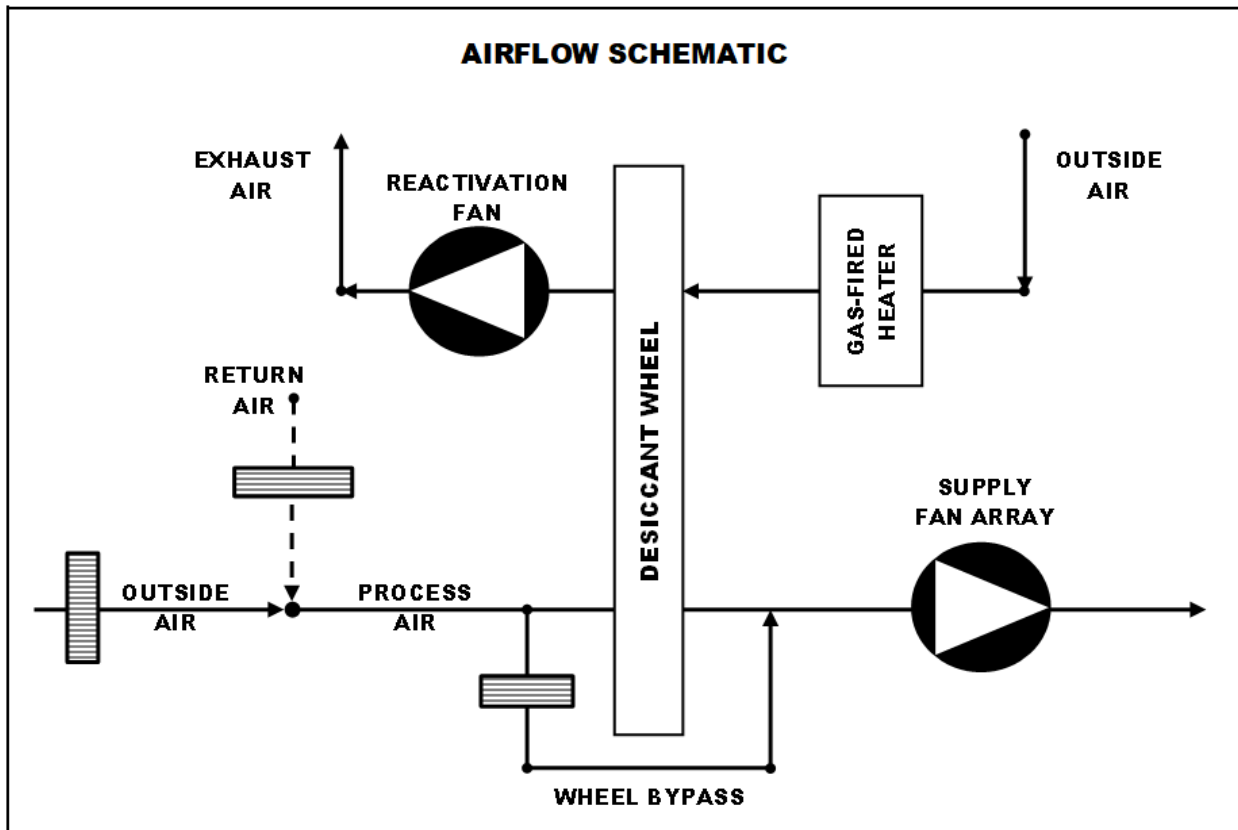

Two (2) separate air streams are integrated into the A-Series units:

- 1) **Process** – process (supply) air is a blend of outside and return air that is conditioned and then delivered to the space. The process airstream consists of a desiccant wheel and a process supply fan array.
- 2) **Reactivation** – the reactivation airstream uses heated outside air to reactivate the desiccant wheel. The reactivation circuit consists of a direct gas-fired heater, desiccant wheel and a reactivation fan.

On a call for dehumidification, the supply fan is energized to draw a blend of outside air and return air from the rink through the desiccant wheel. The desiccant wheel drive motor is energized to rotate the wheel through the process and reactivation air streams at a rate of 8 revolutions per hour. The desiccant draws water vapor from the **process** air stream which is then returned to the rink space at a very low humidity ratio.

During dehumidification mode, the desiccant wheel is continuously regenerated with a separate **reactivation** air stream. Outdoor air is heated by a direct-fire natural gas heater, the heater modulates to maintain the reactivation outlet temperature setpoint (default = 120°F) ensuring the desiccant wheel is thoroughly regenerated. The heated reactivation air drives the moisture from the desiccant and is discharged to the atmosphere.

The dehumidification process is continuous as the desiccant wheel rotates through the supply and reactivation streams. When the rink humidity returns to its control set point, the dehumidifier is de-energized. Unless there is a call for space dehumidification, the desiccant wheel bypass damper remains 100% open to decrease the system air pressure drop and thereby reduce fan motor energy while maintaining the design supply air volume flow rate.

A **Human-Machine Interface (HMI)** is a user-interface that connects the building operator to the unit controller (microprocessor). The A-Series dehumidifier is designed with a touch-screen HMI which is mounted directly within the dehumidification unit to provide local access to review unit performance and operational status. The HMI display allows the building operators to view and modify manufacturer-defined parameters without any computer software.

The unit microprocessor is native BACnet and has BACnet MS/TP protocol capability (IP protocol optional) for integration with a **Building Management System (BMS)**. The unit microprocessor monitors and communicates all appropriate indoor and outdoor conditions, system operation and performance along with both Critical (unit SHUTDOWN) and Non-Critical (unit continues OPERATION) alarms.

SECTION 2: UNIT OPERATION

2.1 Unit Command

The unit has an enable command in the HMI;

1. **On** – the supply fan remains operational at all times and the unit will operate to maintain acceptable indoor air quality and space temperature and humidity levels.
2. **Off** – the unit is disabled and is not permitted to operate even if the space conditions are not satisfied.
3. **Auto (Supply Fan Duty-Cycle)** – upon call for either ventilation, dehumidification, and/or cooling, the supply fan is energized and the unit operates to achieve the space control setpoint(s). Once the control setpoint is satisfied, the supply fan is de-energized.

When the unit is enabled, the supply fan is energized and once process airflow is confirmed via the airflow proving switch, the unit microprocessor status will switch from “*STARTING*” to “*NORMAL*” which will allow the unit to fully-operate to maintain required space conditions. The airflow proving switch must be closed within 2-minutes after the supply fan is energized. Otherwise, the supply fan is de-energized and remains OFF for 2-minutes before the starting sequence is re-initiated. The unit microprocessor will attempt three (3) restarts before the unit is shutdown with a supply airflow lockout alarm.

There are two methods to control the unit:

- a) Direct feedback (hard-wired space sensors to unit microprocessor)
 - Option 1 – Space Sensors (Temp/RH/calculated DP)
 - Option 2 – Return Air Sensors (Temp/RH/calculated DP)

- b) BMS values (space conditions via BACnet interface)

The BMS can enable the unit, provide space condition feedback, monitor unit operation and modify user-adjustable setpoints described in Section 4 of this document.

2.2 Outside & Return Air Dampers

The unit will have an adjustable point to set the minimum value for the outside air damper position. When IAQ sensor levels climb above any of their respective space setpoints, the OA dampers will modulate between the minimum and fully-open position.

The dampers are controlled and prioritized by selecting the maximum signal from each of the following PID loops:

- a) IAQ Mode – When IAQ levels increase above the setpoints, the outdoor air dampers begin to modulate open and the return dampers modulate proportionally close. As IAQ levels decrease below setpoints, the sequence is reversed.
- b) Economizer Mode – When there is a call for Space Cooling only and the outdoor dry-bulb temperature is below the space cooling setpoint, then the outside air and return air damper positions are modulated between the minimum outside air position and fully open outside air position in order to provide outside air for “free” space cooling.

i. Economizer – Space Cooling

The outside air and return air dampers are modulated between the minimum outside air position and fully open outside air position to maintain the economizer supply air cooling temperature setpoint (default = 53°F).

2.3 Dehumidification

The space dew point temperature is calculated by the unit microprocessor based upon feedback from the space dry-bulb temperature and relative humidity sensors. When the space dew point temperature climbs above the space dew point setpoint, the dehumidification mode within the unit is energized. When the dehumidification mode is initiated, the supply fan, the desiccant wheel and reactivation fan are energized.

The dehumidification process is continuous as the desiccant wheel rotates through the supply and reactivation streams. The direct-fire natural gas heater modulates to maintain the reactivation outlet temperature setpoint (factory default = 120°F). Unless there is a call for space dehumidification, the desiccant wheel bypass damper remains 100% open to decrease the system air pressure drop and thereby reduce fan motor energy while maintaining supply air volume flow rate.

The dehumidification mode is de-energized when the space dew point temperature setpoint (default = 39°Fdp) minus the dew point dead-band value (default = 2°F) is achieved. For example, if the space dew point setpoint is 39°F, then the dehumidification mode is energized when the space climbs above 39°Fdp and will continue to operate until the space dew point temperature is lowered to 37°Fdp (space setpoint minus dead-band).

Turbo Mode

If the desiccant unit is not able to achieve the space dew point set point within 1 hour of operation (adjustable), the reactivation outlet temperature setpoint is set to 135°F (adjustable). When the space dew point set point minus the dew point dead-band value is achieved, the dehumidification cycle is disabled. If the dehumidification cycle is enabled again, the reactivation outlet temperature set point is reset to the default value of 120°F.

2.4 Cooling (Future Field Installed Chilled Water Coil)

Upon a rise in space temperature above the space temperature cooling setpoint, the chilled water post-cooling is energized. The desiccant unit microprocessor shall send a modulating control signal to the chilled water cooling coil's fluid flow control valve to maintain a user-adjustable supply air cooling temperature setpoint (default = 53°F).

Cooling is allowed to run at the same time as dehumidification.

The cooling mode is de-energized when the space cooling temperature setpoint (default = 65°F) minus the cooling mode dead-band value (default = 2°F) is achieved. For example, if the space cooling setpoint is 65°F, then the cooling mode is energized when the space temperature rises above 65°F and will continue to operate until the space temperature is lowered to 63°F (space setpoint minus dead-band).

SECTION 3: INDIVIDUAL COMPONENT REVIEW

The following section describes the function of the critical components within the desiccant dehumidification unit.

3.1 Desiccant Wheel, Reactivation Heat and Reactivation Fan

Principle – The operation of a HoneyCombe dehumidifier is based on the principle of adsorption by which a desiccant removes water vapor directly from the air. When the air to be dried passes through the HoneyCombe wheel, the desiccant removes the water vapor directly from the air and holds it while the wheel rotates. As the moisture-laden desiccant passes through the reactivation sector, the water vapor is transferred to a heated air stream which is exhausted to the outdoors. The process is continuous, allowing for uninterrupted dehumidification.

Sequence – On a call for dehumidification, the desiccant wheel drive motor is energized to rotate the wheel through the process and reactivation air streams at a rate of 8 revolutions per hour. The supply fan is energized to draw a blend of outside air and return air from the rink through the desiccant wheel. The desiccant draws water vapor from the process air stream which is then returned to the rink space at a very low humidity ratio. The reactivation circuit, which consists of a constant speed reactivation fan and heater, is energized to draw heated outside air through the desiccant wheel. A direct-fire natural gas heater modulates to maintain the reactivation outlet temperature setpoint (factory default = 120°F).

3.2 ECM Supply Fan Array

When the unit is enabled, the supply fan array is energized and once process airflow is confirmed via the airflow proving switch, the unit microprocessor will then allow the unit to fully-operate in order to maintain acceptable indoor air quality, space temperature and humidity. The airflow proving switch must be closed within 2-minutes after the supply fan is energized. Otherwise, the supply fan is de-energized and remains OFF for 2-minutes before the sequence is re-initiated. The unit microprocessor will attempt three (3) restarts before the unit is shutdown in supply airflow lockout alarm. The alarm must be acknowledged and reset by the building operators in order to restart the unit.

The ECM supply fan array control is designed to deliver a constant process airflow rate to the space. The supply fan has two setpoint values that require adjustment during start-up at the

HMI by the air-balancing technician to provide the design airflow rate while the unit is operating in either dehumidification or non-dehumidification mode (wheel bypass). The unit shall have two sets of supply fan speed values to adjust the unit supply airflow (high / low).

Default Supply Fan Speed Settings

- DH On / DH Off = 8,000 CFM Supply Airflow (Low Setting)
- DH On / DH Off = 16,000 CFM Supply Airflow (High Setting)

3.3 Process Post-Cooling (Future Field Installed Chilled Water Coil)

Upon a call for space cooling, the chilled water cooling coil's fluid flow control valve modulates to maintain the supply air cooling temperature setpoint (default = 53°F). The supply air temperature cooling setpoint is defined by the building operators or BMS.

SECTION 4: USER ADJUSTABLE SETPOINTS

The principal user adjustable setpoints are described in this section. **WARNING** – Other factory default operating parameters not listed below can also be adjusted via the HMI display but it is strongly recommended that these variables only be modified by fully-qualified and fully-trained technicians familiar with the operation of these units. Failure to comply may cause premature breakdown of equipment components which will not be covered under warranty.

4.1 Minimum Outside Air Damper Position

Unit will have an adjustable minimum outside air damper position setpoint (default = 0%). When IAQ levels increase above the setpoints, the outdoor air dampers begin to modulate open and the return dampers modulate proportionally close. As IAQ levels decrease below setpoints, the sequence is reversed.

4.2 Space Dew Point Temperature

The default space dew point temperature setpoint is 39°F.

The unit will continue to dehumidify in favor of the space dew point temperature setpoint minus dead-band (default = 2°F). For instance, if the space dew point setpoint is 39°F, then the dehumidification mode is energized when the space climbs above 39°Fdp and will continue to operate until the space dew point temperature is lowered to 37°Fdp (space setpoint minus dead-band).

4.3 Space Cooling and Supply Air Cooling Temperature

The default space cooling temperature setpoint is 65°F and the default supply air cooling temperature setpoint is 53°F.

The unit will continue cooling in favor of the space cooling setpoint minus dead-band (default = 2°F). For instance, if the space cooling setpoint is 65°F, then the cooling mode is energized when the space temperature rises above 65°F and will continue to operate until the space temperature is lowered to 63°F (space setpoint minus dead-band).

4.4 Space IAQ Setpoints

The unit outdoor and return air dampers will modulate to maintain acceptable indoor air quality based upon the space contaminant level setpoints. Factory default set points for optional space IAQ levels are defined below:

- Carbon Monoxide (CO) = 30 ppm
- Carbon Dioxide (CO₂) = 1200 ppm
- Nitrogen Dioxide (NO₂) = 0.2 ppm

9. Roof Curb Details

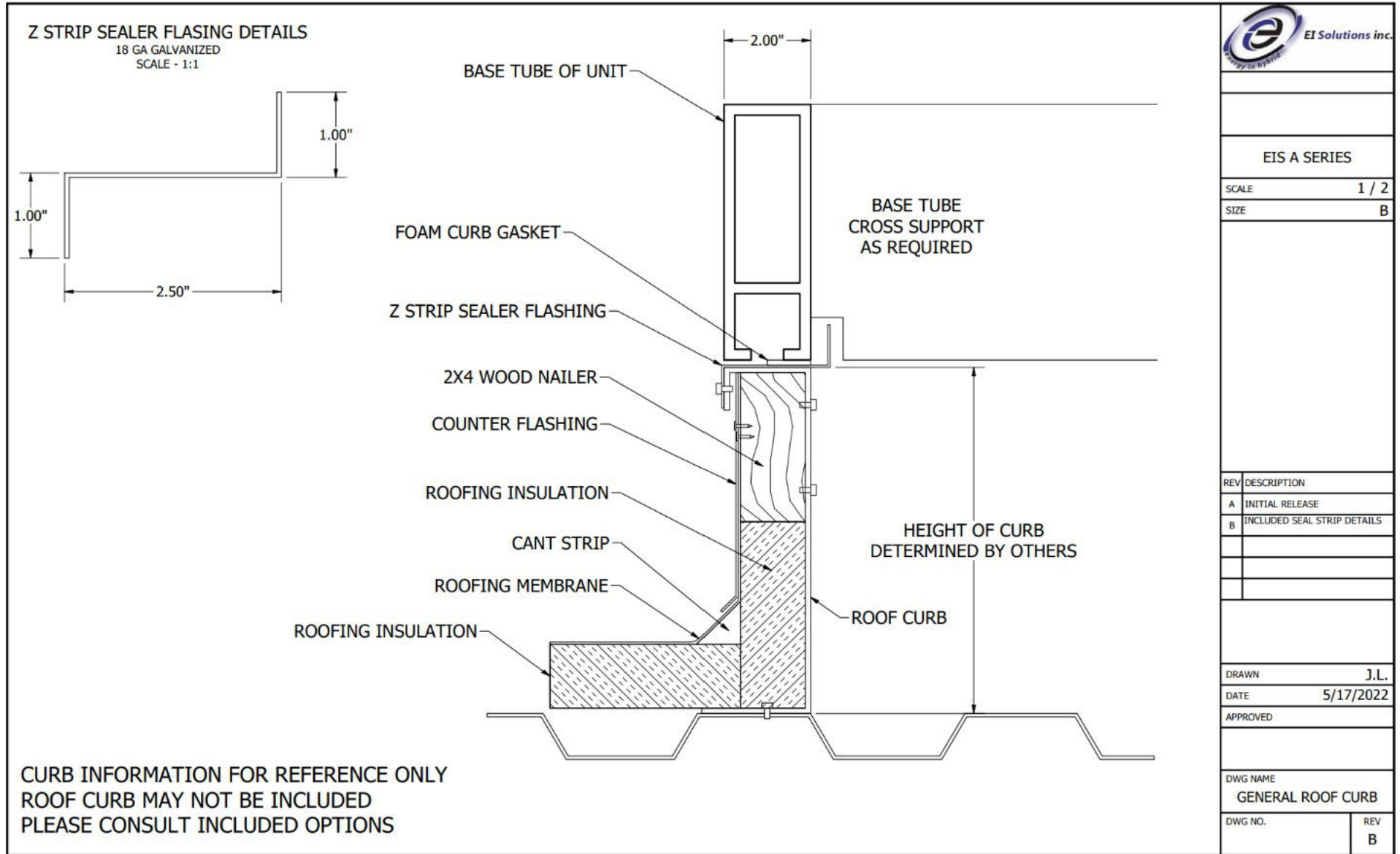

10. Rigging Details

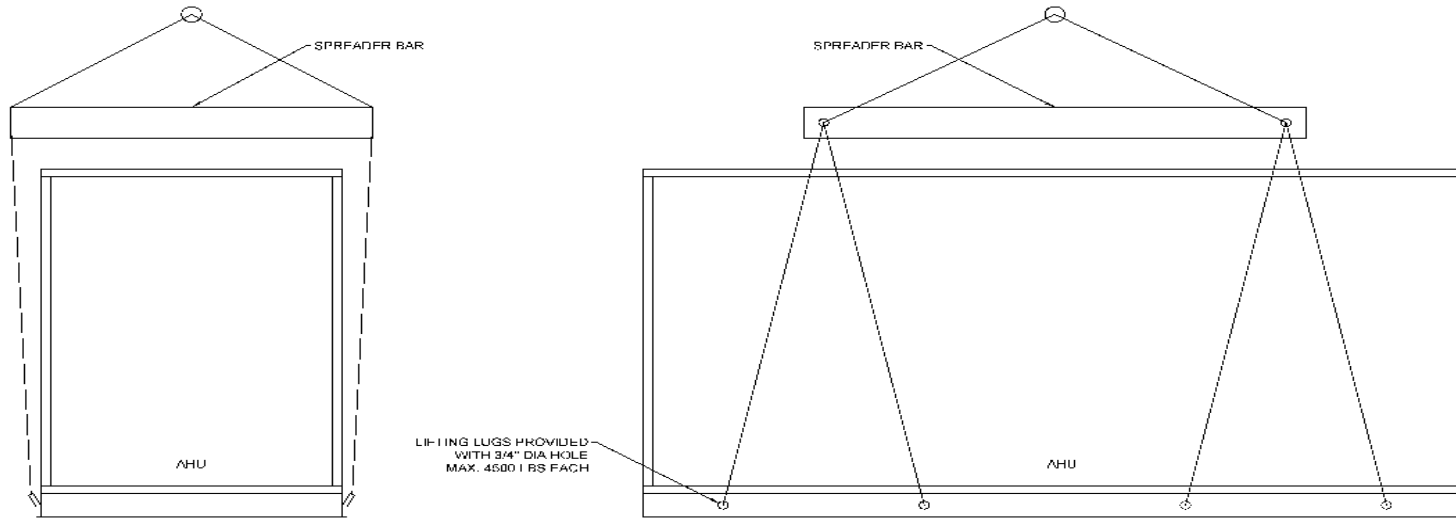

RIGGING DETAIL WILL VARY DEPENDING ON DIMENSIONS AND WEIGHT OF UNIT. SEE EQUIPMENT SCHEDULE FOR UNIT DIMENSIONS AND WEIGHT.

RIGGING DETAIL FOR REFERENCE ONLY

RIGGING TO AVOID CONTACT WITH ALL EQUIPMENT AND HARDWARE PROTRUSIONS TO REDUCE RISK OF DAMAGE TO UNIT. PROVIDE PADDING IF UNAVOIDABLE.

11. Component Details

a) Wall Panel Data Sheet



Technical Data

Nudo AlumaFoam

Nudo AlumaFoam Technical Data

Nudo AlumaFoam panels are insulated composite panels, primarily used within a frame or extrusion. The panels are composed of an insulating foam core laminated between sheet aluminum on the inside and outside of the panel. The aluminum surface may be either embossed or smooth. An EPS (expanded polystyrene) foam is the standard insulating core. Nudo AlumaFoam has a polyester paint finish, available in several standard colors.

Physical Properties: Table 1

Item	Nominal Panel Thickness	Nominal Panel Weight	Color	Size
SN3F94-12-D-PF2-MG WHITE	1"	1.08# psf	Medium Gloss	4'X12'
SN3F144-12-D-PF2-MG WHITE	1.5"	1.21# psf	White	

Physical Properties: Table 2 (Typical Foam Core Properties)

Type of Foam	Characteristics	R-Value Per Inch	Density
Expanded Polystyrene (EPS)	Lightweight	5.26	3#

Typical Applications: Nudo AlumaFoam is an interior panel primarily used as a wall or ceiling panel.

Features: The polyester paint finish comes in several standard colors. The polyester paint finish is protected by a film that pulls away when ready for use. The foam substrate offers insulation properties to the panel that exceed that of other substrates.

Tolerances:

- Thickness: +/- 1/16"
- Width: +0", - 1/8"
- Length: +0", - 1/8"
- Squareness: +/- 1/4"

Storage: Nudo AlumaFoam Panels should always be stored flat on a smooth surface above the ground. A pallet with a smooth piece of plywood beneath the panels is best to avoid any warping or waviness. As with most building products, it is best to acclimate the panel on site 48 hours before installation. Although the panels are moisture resistant, be sure panels are kept dry prior to installation to ensure water is not trapped under the protective film.

Handling: Although AlumaFoam panels are rigid and have good impact resistance, the aluminum faces can be scratched or dented if not handled properly. Do not drop or bump the panel on its edges as this may cause unwanted bending of the aluminum. Do not slide the panel edges or face over rough surfaces that may cause bending or scratching. Pick panels up when handling as compared to sliding panels across each other. Sliding panels may cause scratches on one or both faces.

Optimization: When performing panel optimizations for the purpose of cutting panels to size, always check to ensure if the surface finish is "directional". Some finishes require the panels to be installed so all panel surfaces run the same direction.



NUDO® • 1500 Taylor Avenue Springfield, Illinois 62703 • 800-826-4132



Technical Data

Nudo AlumaFoam

Fabrication: Use protective eyewear such as goggles or safety glasses, cover your nose and mouth with a filter mask when cutting Nudo AlumaFoam Panels.

- Always position the panel so the saw blades enter the exterior side first to avoid chipping and damage.
- Cutting: Use a circular saw with a 72-tooth carbide tipped blade.

Cleaning & Maintenance: The Nudo AlumaFoam panel requires almost no maintenance. If the surface does need to be cleaned, use a mild cleaning detergent with water.



Disclaimer: We believe all information given is accurate. It is offered in good faith, but without guarantee. Since conditions of use are beyond our control, the user assumes all risks. Nothing herein shall be construed as a recommendation for use that infringes on valid patent or as extending a license under valid permit.



NUDO[®] • 1500 Taylor Avenue Springfield, Illinois 62703 • 800-826-4132

b) Damper Data Sheet



3960
Duct-Mount

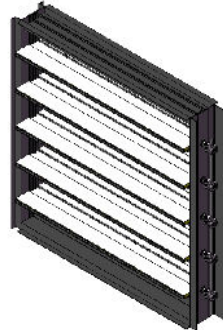

3961 Quick 'N' Stall
Duct-Mount

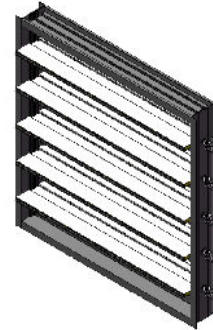

3965
Flanged-to-Duct

STANDARD CONSTRUCTION
Depth: 4" (101 mm) – 3960/3965
5.25" (133 mm) – 3961
Depth with Blades Open: 6.125" (156 mm)
Minimum Height: 8" (203 mm) - Single Blade
15" (381 mm) - Multiple Blade
Maximum Panel Width: 48" (1219 mm)
Maximum Panel Height: 60" (1524 mm)
Maximum Panel Size: 20 Sq.Ft.
Maximum System Pressure: 4" w.g. (1 kPa)
Operating Temperature Range: -40° to +180° F
Standard Finish: Mill
Standard Motor Installation: 6" Side Shaft Direct Drive
Linkage: Concealed in Frame (3960/3961)
Outside of Frame (3965)

AVAILABLE ACCESSORIES
• Factory Supplied/Installed Actuators
• End Switch for signaling peripheral devices
• Jack Shaft
• Hand Quadrants
• Chain Operation for manual operation spring closed
• Silicone Blade and Jamb Seals – Specify 3900SI
• Salt Water Construction – Specify 3900SW
• Available finish: Clear Anodized
• Frame Insulation: Polystyrene Insulation

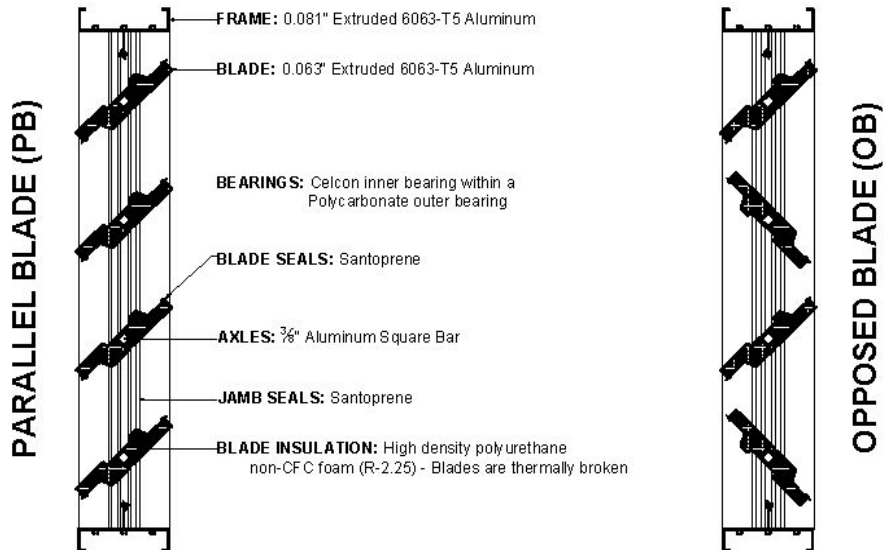

DWG. 3960-3961-3965 JAN 2020

222 CHURCH ST S | ALLISTON, ON. L9R 2B7 | TEL (905) 857-4700 | FAX (905) 857-4730 | 1-800-668-7214 | www.ventexinc.com

141

ALUMAVENT
CONTROL DAMPERS & FIRE DAMPERS

3900 SERIES
INSULATED CONTROL DAMPERS
3960 | 3961 | 3965

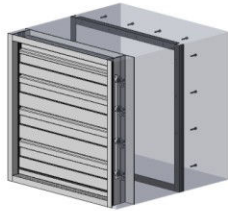

3960 – Duct-Mount

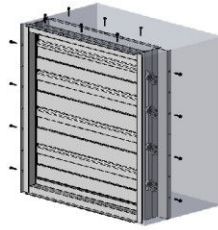

3961 – Duct-Mount

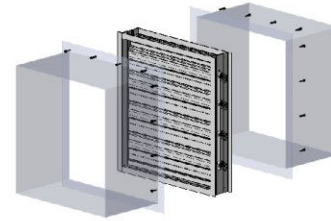

3965 – Flanged-to-Duct

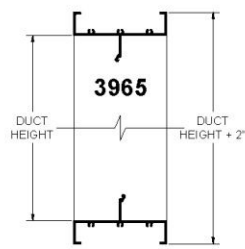
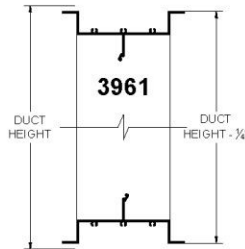
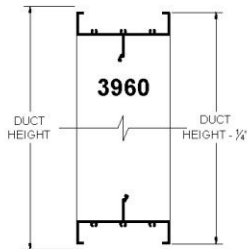

For Duct-Mount Frame specify: 3960 / 3961
For Flanged-to-Duct Frame specify: 3965

RECOMMENDED SPECIFICATION

Furnish and install control damper models 3960 / 3961 / 3965 as manufactured by Alumavent, Bolton Ontario. Dampers shall be 4" (101 mm) deep. Blades shall be 0.063" (1.60 mm) thick, thermally broken with high density Polyurethane non-CFC injected foam insulation. Frame shall be 0.081" (2.06 mm) thick, with polystyrene insulation. Axles shall be 0.375" (9.53 mm) thick, Aluminum square bar. Blade and Jamb seals shall be Santoprene. Linkage is concealed in frame for models 3960 / 3961 and outside of frame for model 3965. Air leakage through a 36"x36" (914 mm x 914 mm) damper shall not exceed 3 CFM/R² (15.2 L/s/m²) against 4" w.g (1.0 kPa) static pressure at standard air (as per AMCA testing). Operating temperature range shall be -40° to +190° F.

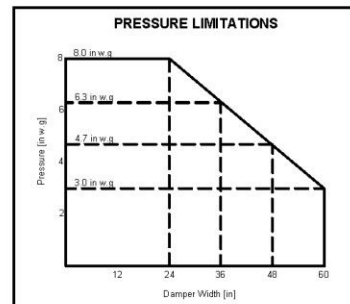

DWG. 3960-3961-3965 JAN 2020

222 CHURCH ST S | ALLISTON, ON. L9R 2B7 | TEL (905) 857-4700 | FAX (905) 857-4730 | 1-800-668-7214 | www.ventexinc.com

[2]

ALUMAVENT

CONTROL DAMPERS & FIRE DAMPERS

3900 SERIES

INSULATED CONTROL DAMPERS
3960 | 3961 | 3965

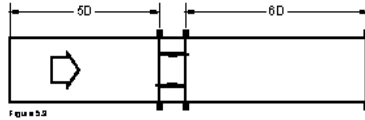

3900 SERIES CONTROL DAMPER PRESSURE DROP	
Velocity [FPM]	Pressure Drop [in. w.g.]
12x12 (inches)	
553.6	0.044
891.4	0.119
1051.9	0.161
2021.4	0.554
2221.7	0.740
24x24 (inches)	
536.8	0.014
776.9	0.025
1101.1	0.056
2066.3	0.182
2530.1	0.272
36x36 (inches)	
500.4	0.01
750.6	0.021
1006.1	0.036
2019.5	0.161
2526.6	0.249
12x48 (inches)	
545	0.008
772.8	0.018
1095.3	0.035
2055.5	0.126
2519.2	0.187
48x12 (inches)	
544.6	0.029
772.2	0.064
1094.4	0.1228
2053.1	0.439
2516	0.661

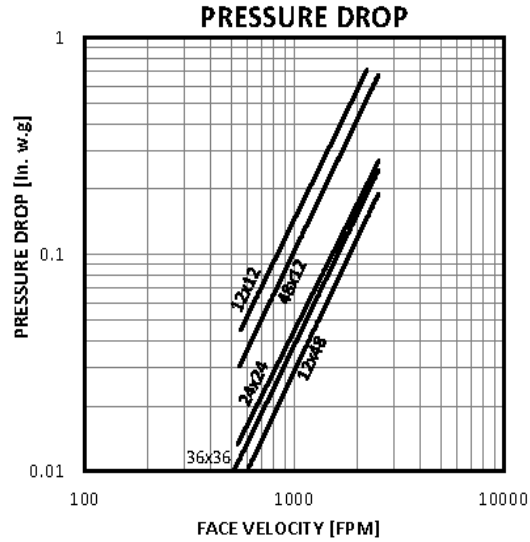

Ratings Based on: AMCA Standard 500-D Intake Ducted Test Figure 5.3 Setup

DEFINITION OF LEAKAGE CLASSIFICATION				
CLASS	LEAKAGE ft ³ /min/ft ² (L/s/m ²)			
	1" (0.25 kPa)	4" (1.0 kPa)	8" (2.0 kPa)	12" (3.0 kPa)
1A	3 (15.2)	N/A	N/A	N/A
1	4 (20.3)	8 (40.6)	11 (55.9)	14 (71.1)
2	10 (50.8)	20 (102)	28 (142)	35 (178)
3	40 (203)	80 (406)	112 (569)	140 (711)

3900 SERIES CONTROL DAMPER LEAKAGE RATING			
DAMPER SIZE Width x Height	PRESSURE in wg (kPa)		
	1" (0.25 kPa)	4" (1.0 kPa)	8" (2.0 kPa)
12"x12" (305x305 mm)	1A	1	1
24"x24" (610x610 mm)	1A	1	1
36"x36" (914x914 mm)	1A	1	1
12"x48" (305x1219 mm)	1A	1	1
48"x12" (1219x305 mm)	1A	1	1
48"x36" (1219x914 mm)	1A	1	1

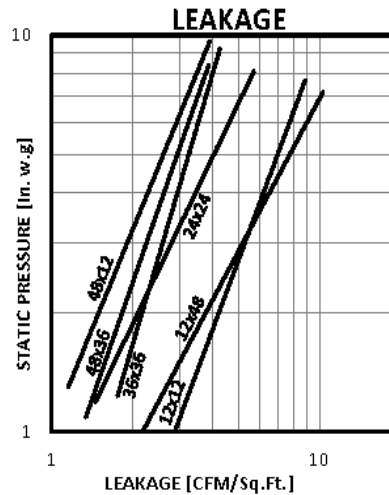

Leakage test was conducted in accordance with AMCA Standard 500-D-98. Holding torque applied was 6 in.-lbs./sq. ft on parallel blade dampers. AMCA Standard 500-D-98 states that air leakage is based on operation between 50°F (10°C) and 104°F (40°C).

DWG. 3960-3961-3965 JAN 2020

c) Filter – Merv 8 Data Sheet



PRODUCT OVERVIEW

- Standard Capacity (MERV 8) & High Capacity (MERV 10)
- Available in 1", 2" & 4" depths
- Ideal for use in
 - Prefilter for high efficiency filters
 - Office and Retail
 - Manufacturing and Distribution
 - Government and Education facilities
 - Doctor offices, assisted living facilities and Hospitals
 - Hotels and Airports
 - Single and Multi-Family Housing

AEROSTAR SERIES 400 PLEAT

WHY THE SERIES 400?

- 100% synthetic pleated media achieves exceptionally high levels of efficiency
 - Does not rely on electrostatic charge
 - Low resistance to air flow means minimal energy costs
 - Moisture resistant and will not promote microbial growth
 - Excellent pre-filter for higher efficiency air filters
 - Effectively removes airborne irritants
 - Protects cooling coils & ductwork of HVAC system
- Durable construction optimizes performance
 - Media laminated to metal grid
 - Minimized media fluttering
 - Design helps maintain pleat uniformity
 - Frame constructed of high wet strength beverage board
 - Will not warp, crack or distort under normal operating conditions

AEROSTAR[®] SERIES 400 PLEAT

PERFORMANCE DATA (24 x 24)

CAPACITY	FILTER DEPTH	INITIAL RESISTANCE (°w.g.)				FINAL RESISTANCE (°w.g.)
		300 fpm	375 fpm	500 fpm	625 fpm	
Standard MERV 8	1"	0.14	0.21	—	—	1.0
	2"	—	0.14	0.20	0.27	1.0
	4"	—	0.09	0.14	0.21	1.0

CAPACITY	FILTER DEPTH	INITIAL RESISTANCE (°w.g.)				FINAL RESISTANCE (°w.g.)
		300 fpm	375 fpm	500 fpm	625 fpm	
High MERV 10	1"	0.20	0.28	—	—	1.0
	2"	—	0.16	0.24	0.32	1.0
	4"	—	0.08	0.17	0.26	1.0

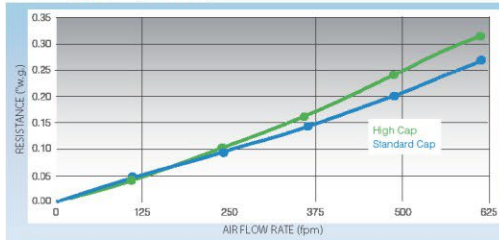
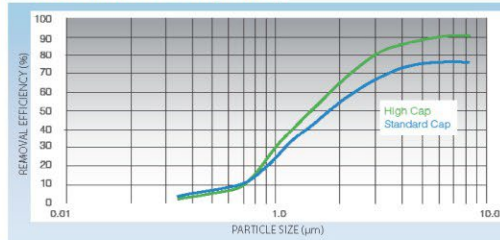
INITIAL RESISTANCE (24 x 24 x 2)

MINIMUM REMOVAL EFFICIENCY (24 x 24 x 2)

PRODUCT DATA

STD CAP	HIGH CAP	NOMINAL SIZE* (H" x W" x D")	ACTUAL SIZE (H" x W" x D")	CFM CAPABILITIES	
				300 fpm	375 fpm
10403	10476	8 x 16 x 1	7 3/4 x 15 3/4 x 3/4	250	325
10404	10477	10 x 10 x 1	9 1/2 x 9 1/2 x 3/4	200	250
10364	10436	10 x 20 x 1	9 1/2 x 19 1/2 x 3/4	400	525
10405	10478	10 x 24 x 1	9 3/8 x 23 3/8 x 3/4	500	625
10406	10479	10 x 25 x 1	9 3/4 x 24 3/4 x 3/4	525	650
10365	10437	12 x 12 x 1	11 3/4 x 11 3/4 x 3/4	300	375
10407	10480	12 x 16 x 1	11 1/2 x 15 1/2 x 3/4	400	500
10366	10438	12 x 20 x 1	11 1/2 x 19 1/2 x 3/4	500	625
10367	10439	12 x 24 x 1	11 1/2 x 23 1/2 x 3/4	600	750
10368	10440	12 x 25 x 1	11 1/2 x 24 1/2 x 3/4	625	775
10369	10441	14 x 20 x 1	13 1/2 x 19 1/2 x 3/4	575	725
10408	10481	14 x 24 x 1	13 1/2 x 23 1/2 x 3/4	700	875
10370	10442	14 x 25 x 1	13 1/2 x 24 1/2 x 3/4	725	900
10371	10443	15 x 20 x 1	14 1/2 x 19 1/2 x 3/4	625	775
10409	10482	15 x 25 x 1	14 1/2 x 24 1/2 x 3/4	800	975
10410	10483	16 x 16 x 1	15 3/4 x 15 3/4 x 3/4	525	650
10372	10444	16 x 20 x 1	15 1/2 x 19 1/2 x 3/4	650	825
10411	10484	16 x 24 x 1	15 1/2 x 23 1/2 x 3/4	800	1000
10373	10445	16 x 25 x 1	15 1/2 x 24 1/2 x 3/4	825	1050
10412	10485	18 x 18 x 1	17 3/4 x 17 3/4 x 3/4	675	850
10413	10486	18 x 20 x 1	17 1/2 x 19 1/2 x 3/4	750	925
10414	10487	18 x 22 x 1	17 1/2 x 21 1/2 x 3/4	825	1025
10415	10488	18 x 24 x 1	17 1/2 x 23 1/2 x 3/4	900	1125
10374	10446	18 x 25 x 1	17 1/2 x 24 1/2 x 3/4	925	1175
10375	10447	20 x 20 x 1	19 1/2 x 19 1/2 x 3/4	825	1050
10416	10489	20 x 24 x 1	19 1/2 x 23 1/2 x 3/4	1000	1250
10376	10448	20 x 25 x 1	19 1/2 x 24 1/2 x 3/4	1050	1300
10417	10490	22 x 22 x 1	21 3/4 x 21 3/4 x 3/4	1000	1250
10377	10449	24 x 24 x 1	23 1/2 x 23 1/2 x 3/4	1200	1500
10378	10450	25 x 25 x 1	24 1/2 x 24 1/2 x 3/4	1300	1625

* Contact Customer Care for additional sizes and information.

STD CAP	HIGH CAP	NOMINAL SIZE* (H" x W" x D")	ACTUAL SIZE (H" x W" x D")	CFM CAPABILITIES	
				375 fpm	500 fpm
10418	10491	10 x 10 x 2	9 3/4 x 9 3/4 x 1 3/4	250	350
10379	10451	10 x 20 x 2	9 1/2 x 19 1/2 x 1 3/4	525	700
10419	10492	12 x 20 x 2	11 1/2 x 19 1/2 x 1 3/4	625	825
10380	10452	12 x 24 x 2	11 3/8 x 23 3/8 x 1 3/4	750	1000
10381	10453	14 x 20 x 2	13 1/2 x 19 1/2 x 1 3/4	725	975
10382	10454	14 x 25 x 2	13 1/2 x 24 1/2 x 1 3/4	900	1200
10383	10455	15 x 20 x 2	14 1/2 x 19 1/2 x 1 3/4	775	1025
10420	10493	16 x 16 x 2	15 1/2 x 15 1/2 x 1 3/4	650	875
10384	10456	16 x 20 x 2	15 1/2 x 19 1/2 x 1 3/4	825	1100
10385	10457	16 x 24 x 2	15 3/8 x 23 3/8 x 1 3/4	1000	1325
10386	10458	16 x 25 x 2	15 1/2 x 24 1/2 x 1 3/4	1050	1400
10421	10494	18 x 22 x 2	17 1/2 x 21 1/2 x 1 3/4	1025	1375
10387	10459	18 x 24 x 2	17 3/8 x 23 3/8 x 1 3/4	1125	1500
10422	10495	18 x 25 x 2	17 1/2 x 24 1/2 x 1 3/4	1175	1550
10388	10460	20 x 20 x 2	19 1/2 x 19 1/2 x 1 3/4	1050	1400
10389	10461	20 x 24 x 2	19 3/8 x 23 3/8 x 1 3/4	1250	1650
10390	10462	20 x 25 x 2	19 1/2 x 24 1/2 x 1 3/4	1300	1750
10391	10463	24 x 24 x 2	23 3/8 x 23 3/8 x 1 3/4	1500	2000
10392	10464	25 x 25 x 2	24 1/2 x 24 1/2 x 1 3/4	1625	2150
10393	10465	12 x 24 x 4	11 3/8 x 23 3/8 x 3 3/4	500 fpm	625 fpm
10394	10466	16 x 20 x 4	15 1/2 x 19 1/2 x 3 3/4	1000	1250
10395	10467	16 x 25 x 4	15 1/2 x 24 1/2 x 3 3/4	1100	1400
10396	10468	18 x 24 x 4	17 3/8 x 23 3/8 x 3 3/4	1400	1750
10397	10469	20 x 20 x 4	19 1/2 x 19 1/2 x 3 3/4	1500	1875
10398	10470	20 x 24 x 4	19 3/8 x 23 3/8 x 3 3/4	1650	2100
10399	10471	20 x 25 x 4	19 1/2 x 24 1/2 x 3 3/4	1750	2200
10400	10472	24 x 24 x 4	23 3/8 x 23 3/8 x 3 3/4	2000	2500
10401	10473	25 x 29 x 4	24 3/8 x 28 3/8 x 3 3/4	2525	3150
10404	10474	28 x 30 x 4	27 3/8 x 29 3/8 x 3 3/4	2900	3650

ENGINEERING SPECIFICATIONS
1.0 General

- 1.1 Filters shall be Aerostar[®] Series 400 extended surface pleated air filters as manufactured by Filtration Group.
- 1.2 Filters shall be available in standard and high capacity configurations and available in nominal depths of 1", 2", and 4".
- 1.3 Underwriters Laboratories classified to UL 900 and ULC-S111-07.
- 1.4 Filters are manufactured by an ISO 9001 registered company.

2.0 Filter Materials of Construction

- 2.1 Media shall be 100% synthetic, mechanical media that does not support microbial growth.
- 2.2 Filters shall have a high wet strength beverage board with a cross member design that increases filter rigidity and prevents breaching. Frame shall be recyclable.

- 2.3 Filters shall have an expanded metal support grid bonded to the air-exiting side of the filter to maintain pleat uniformity and prevent fluttering. Metal support grid shall be recyclable and contain a significant amount of post-consumer and pre-consumer content.

3.0 Filter Performance

- 3.1 Filters shall be MERV 10/10A in a high capacity configuration and MERV 8/8A in a standard capacity configuration when tested in accordance with ASHRAE 52.2 Test Standard.
- 3.2 For initial resistance of filters, see Performance Data chart above.
- 3.3 Filters shall be rated to withstand a continuous operating temperature up to 200°F.
- 3.4 Filters shall have a recommended final resistance of 1.0° w.g.

United States • Phone: +1 800 739-4600 • aerostar@filtrationgroup.com | Canada • Phone: +1 888 628-3458 • inquirycanada@filtrationgroup.com

FiltrationGroupIAQ.com

©FG 07/20



d) Supply Fan Data Sheet
1

type	GR50C-4DM.H2.CR*
article no.	115205/HA03 Portfolio AMCA USA G1

technical data

motor	ZAmotpremium PE
Efficiency class	PEM
power output ($P_{2\text{ main}}$)	hp 10
mains supply	3~ 460V 60Hz Y
nominal current (I_N)	A 12.50
motor efficiency grade (η_M)	% 91.7
ambient temperature, max. limit (t_r)	°C 40
grille influence	no

fan data

SFP-class SFP-value (P_{SFP})	- Ws/m ³	5 2379
FEG	%	85
FEI	-	1.35
airflow volume (q_v)	ft ³ /min	5333.0
air velocity	ft/s	34.09
pressure, stat. (p_{sF}) tot. (p_F)	in.wg.	6.050 6.307
electrical power input (P_{sys})	W	5987
system eff., stat. ($\eta_{\text{sF,sys}}$) tot. ($\eta_{\text{F,sys}}$)	%	63.4 66.0
electrical power input (P_1)	W	5807
efficiency grade, stat. (η_{sF}) tot. (η_F)	%	65.3 68.1
shaft power (P_L) max. ($P_{L\text{ max}}$)	W	5322 5398
impeller eff., stat. ($\eta_{\text{sF,L}}$) tot. ($\eta_{\text{F,L}}$)	%	71.3 74.3
fan speed (n) max. (n_{max})	rpm	2256 2450
fan speed, set value ($\%n_{\text{max}}$)	%	92
frequency (f_{DP}) (f_{max})	Hz	76 83
voltage (U_{DP})	V	460
acoustics, suction side ($L_{\text{w(A),5}}$) ($L_{\text{w,5}}$)	dB	87 92
acoustics, pressure side ($L_{\text{w(A),6}}$) ($L_{\text{w,6}}$)	dB	97 101
dimensions (w x h x d)	in	26.38 x 26.38 x 28.58
product weight (m_{pr})	lb	229.3
k-factor nozzle pres. (k)	-	252
differential pres. nozzle ($p_{\text{sF nozzle}}$)	Pa	1293

nominal values

3~ 208-230V D 60Hz P2 10HP
 26.00A 1770/MIN 40°C
 3~ 460V Y 60Hz P2 10HP
 12.50A 1770/MIN 40°C
 OPSB THCL155
 fan speed, max. (n_{max}) 2450 1/min

PF:PF_03; BR:BR_17; qv:1177.2 ft³/min; p_r:0.201 in.wg.; t:68 °F; p:0.072 lbs/ft³; STol:+-10 %

FANselect

performance curve / acoustics

17.12.2024

Version: FANselect V 1.01 (241217), AMCA V 1.03 September, 2021->br>RLT V 1.00 Dezember, 2021 / 1.24.12.17 | 30211 | (user ZAFS20211)

- 1 **GR50C-4DM.H2.CR*** measured in standard nozzle in installation type A according to ISO 5801
 115205/HA03 | Portfolio measurement density 0.074 [lbs/ft³]
 AMCA USA G1

air performance p_{sF}

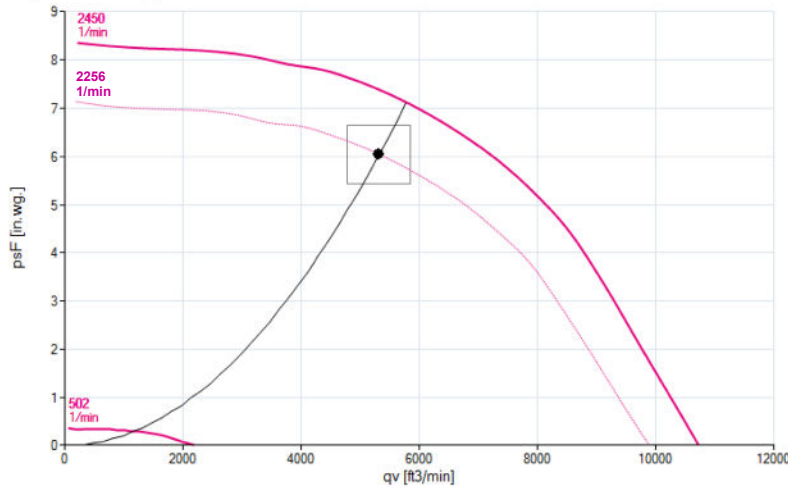

acoustics (L_{w(A),5})

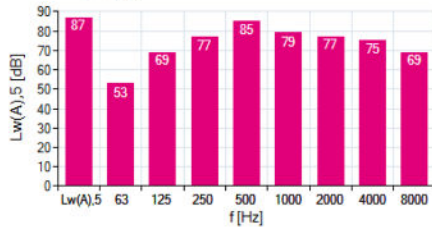

acoustics (L_{w(A),6})

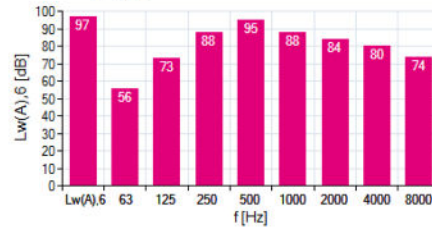

1 GR50C-4DM.H2.CR*									
f [Hz]	sum	63	125	250	500	1000	2000	4000	8000
L _{w(A),5}	87	53	69	77	85	79	77	75	69
L _{w,5}	92	78	85	85	88	79	76	74	70

1 GR50C-4DM.H2.CR*									
f [Hz]	sum	63	125	250	500	1000	2000	4000	8000
L _{w(A),6}	97	56	73	88	96	88	84	80	74
L _{w,6}	101	81	89	97	98	88	83	79	75

e) Reactivation Fan Data Sheet

FAN DETAILS		Job Name: 2024 ESC - October Update																													
		Tag: A35 - 4500 CFM 5.23" 575 Customer: Environmental Systems Corporation Job ID: 8011064-1OctoberUpdate Date: December 18, 2024																													
Description		Performance																													
Quantity 1	Volumetric Flow CFM 4,500	<table border="1" style="width: 100%; border-collapse: collapse;"> <thead> <tr style="background-color: #4a86e8; color: white;"> <th colspan="2" style="padding: 5px;">Air/Gas Properties</th> </tr> </thead> <tbody> <tr><td style="padding: 5px;">Altitude above sea level (ft) 0</td></tr> <tr><td style="padding: 5px;">Inlet Pressure (in WC) 0.000</td></tr> <tr><td style="padding: 5px;">Inlet Temperature(°F) 135</td></tr> <tr><td style="padding: 5px;">Design Temperature (°F) 140</td></tr> <tr><td style="padding: 5px;">Gas Type Operating air</td></tr> <tr><td style="padding: 5px;">Estimated Density (lb/ft³) 0.0626</td></tr> </tbody> </table>		Air/Gas Properties		Altitude above sea level (ft) 0	Inlet Pressure (in WC) 0.000	Inlet Temperature(°F) 135	Design Temperature (°F) 140	Gas Type Operating air	Estimated Density (lb/ft³) 0.0626																				
Air/Gas Properties																															
Altitude above sea level (ft) 0																															
Inlet Pressure (in WC) 0.000																															
Inlet Temperature(°F) 135																															
Design Temperature (°F) 140																															
Gas Type Operating air																															
Estimated Density (lb/ft³) 0.0626																															
Model BC-SW	Operating SP (in WC) 5.230																														
Size 165	Standard SP (in WC) 6.270																														
Width SWSI	RPM 2834																														
Arrangement 4	Tip Speed (FPM) 12242																														
Class II	Oper. Power BHP 6.00																														
Rotation CCW	Standard Power BHP 7.19																														
Discharge THD	Outlet Area (sq.ft) 1.57																														
Wheel Diameter (in) 16.5	Outlet Velocity (FPM) 2866																														
Drive method Direct	Max RPM for Class 3042																														
Percentage width 100%	Static Efficiency 61.87%																														
Percentage diameter 100%	Total Efficiency 66.92%																														
Motor position --	FEI 1.19																														
Design VFD Op. Freq 49hz	FEP (KW) 4.93																														
	System FEI 1.19																														
	System FEP (KW) 4.93																														
	CA T20 Compliant/Exempt Yes																														
Modifiers		Motor Data																													
Using VFD.		Power (HP) 10																													
		Enclosure TEFC																													
		Speed (RPM) 3600																													
		Voltage 575V																													
		Phase 3																													
		Frequency 60Hz																													
		Frame Size 215T																													
		Technology																													
Sound																															
<table border="1" style="width: 100%; border-collapse: collapse; text-align: center;"> <thead> <tr style="background-color: #4a86e8; color: white;"> <th style="padding: 5px;">Octave Bands</th> <th style="padding: 5px;">1</th> <th style="padding: 5px;">2</th> <th style="padding: 5px;">3</th> <th style="padding: 5px;">4</th> <th style="padding: 5px;">5</th> <th style="padding: 5px;">6</th> <th style="padding: 5px;">7</th> <th style="padding: 5px;">8</th> <th style="padding: 5px;">LwA</th> </tr> </thead> <tbody> <tr style="background-color: #4a86e8; color: white;"> <th style="padding: 5px;">Level at Inlet</th> <td style="padding: 5px;">99</td> <td style="padding: 5px;">91</td> <td style="padding: 5px;">94</td> <td style="padding: 5px;">97</td> <td style="padding: 5px;">95</td> <td style="padding: 5px;">90</td> <td style="padding: 5px;">88</td> <td style="padding: 5px;">86</td> <td style="padding: 5px;">99</td> </tr> </tbody> </table>		Octave Bands	1	2	3	4	5	6	7	8	LwA	Level at Inlet	99	91	94	97	95	90	88	86	99	<table border="1" style="width: 100%; border-collapse: collapse; text-align: center;"> <thead> <tr style="background-color: #4a86e8; color: white;"> <th style="padding: 5px;">Distance in ft</th> <th style="padding: 5px;">1</th> <th style="padding: 5px;">3</th> <th style="padding: 5px;">5</th> </tr> </thead> <tbody> <tr style="background-color: #4a86e8; color: white;"> <th style="padding: 5px;">dBA at inlet</th> <td style="padding: 5px;">99</td> <td style="padding: 5px;">89</td> <td style="padding: 5px;">85</td> </tr> </tbody> </table>		Distance in ft	1	3	5	dBA at inlet	99	89	85
Octave Bands	1	2	3	4	5	6	7	8	LwA																						
Level at Inlet	99	91	94	97	95	90	88	86	99																						
Distance in ft	1	3	5																												
dBA at inlet	99	89	85																												
Sound Power Levels in dB re.10 ⁻¹² Watts:		Estimated sound pressure level in dBA (re: 0.0002 microbar) based on a single * ducted installation:																													
*To estimate dBA level for ducted inlet and ducted outlet (into and out of the room) type installation, deduct 20 from the LwA value shown. Using a directivity factor of 1. Estimated Sound Pressure based on free field, spherical (Q = 1) radiation at stated distance.																															
Definitions:																															
LwA The overall (single value) fan sound power level, 'A' weighted.																															
dBA The environment for each fan installation influences its measured sound value, therefore dBA levels cannot be guaranteed. Consult AMCA Publication 303 for further details. A fan's dBA is influenced by nearby reflective surfaces.																															
<hr/> Ver 10.2 July 2022 - Created 10-02-2024 Updated 12-18-2024 Owner Peter Hinahara Le Groupe Master Inc. Page 1 of 2 All quotations per Twin City Fan & Blower Terms and Conditions found at www.tcf.com/terms-and-conditions																															

Job Name: 2024 ESC - October Update



Customer: Environmental Systems Corporation
Job ID: 8011064-1OctoberUpdate
Date: December 18, 2024

Tag: A35 - 4500 CFM 5.23" 575

Fan information

Size/Model	165/BC-SW	Class	II	FEI	1.19
Volumetric Flow (CFM)	4500	Speed (RPM)	2834	System FEI	1.19
SP (in WC)	5.23	Max Speed	3,042 RPM @ 140 °F	FEP (KW)	4.93
		Power (BHP)	6	System FEP (KW)	4.93
		Outlet Vel (FPM)	2866	CA T20 Compliant/Exempt . . .	Yes
		Density (lb/ft ³)	0.0626		

Adjusted for Op temp: 135°F, Design temp: 140°F, Humidity: 95%

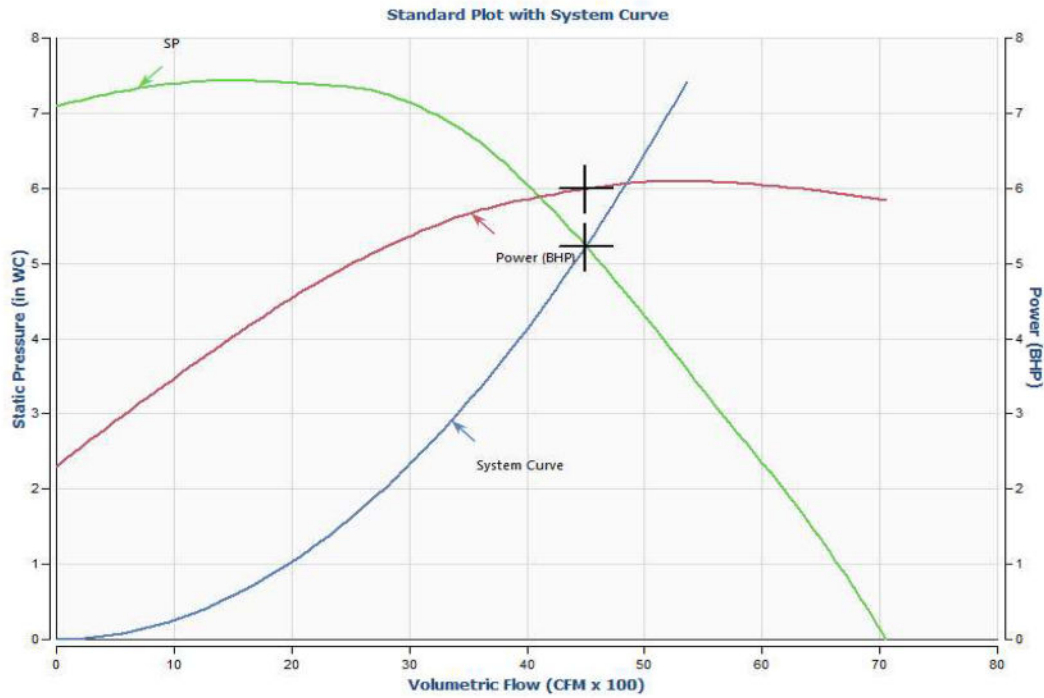

f) Desiccant Wheel Motor Data Sheet

MOTOR	
PRODUCT SERIES	BE - AC IE2 Three Phase Motor
FRAME SIZE	63A - Motor Size 63A
POLE NUMBER	4 - 4 Poles
VOLTAGE-FREQUENCY	230/460-60 - 230 [V] Δ - 460 [V] Y 60 [Hz]
DEGREE OF PROTECTION	IP55 - Standard and Brake Motors
INSULATION CLASS	CLF - Standard Insulation Class
MOUNTING	B5 - B5 Motor Mounting Flange
TECHNICAL DATA	
n Motor Speed [min-1]	1700
Mn Motor Nominal Torque [Nm]	0.67
Tn Motor Nom. Torque [lb-in]	5.9
η₁₀₀ Efficiency 100% [%]	64.8
In 460V Nomin.Curren.@ 460V[A]	0.41
Cosφ	0.61
Pn Motor Nominal Power [kW]	0.12
Pn Motor Nominal Power [Hp]	0.16
Motor Weight [Kg]	3.5
Motor Weight [lb]	7.7

g) Desiccant Wheel 2D Drawing

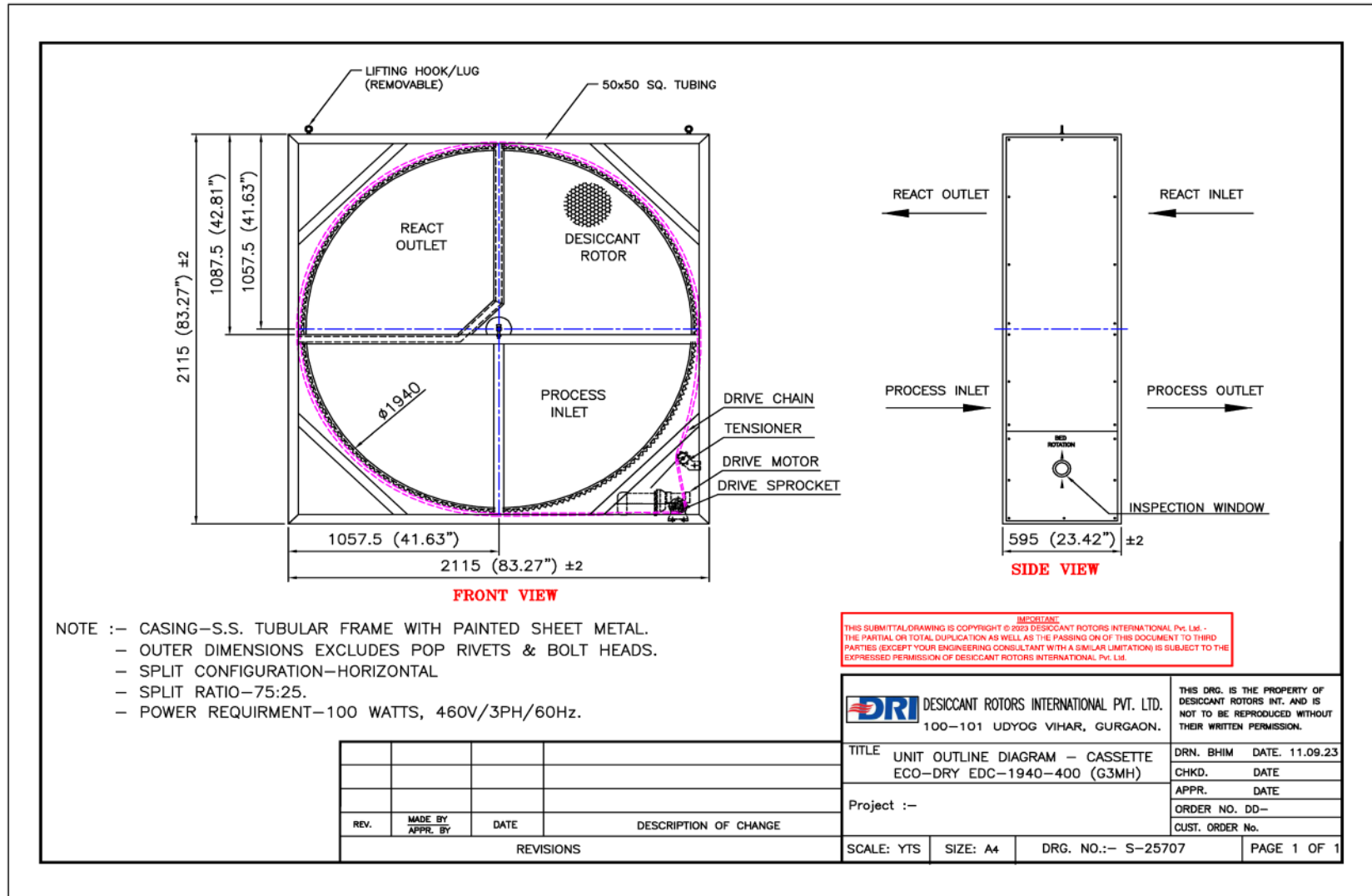

h) Direct Heater Data Sheet



Unit Data Sheet - DF Direct Gas-Fired Heat Module

 Report Created: 9/27/2024
 Created By: Sean Baxter
 Work Order #:

 Customer: ESC
 ATTN: Thomas Ring
 Project: 23-1292
 Unit Tag: A-35

 Serial #: _____
 Unit Model: DF-04-549GV2CCA0DN1C2SVVC QTY: 1

CONFIGURATION

 Location: Outdoor
 Application: Process
 Configuration (Airflow): Left to Right
 Vestibule: VC (Full Vestibule w/ doors)
 Altitude: 0 ft

ELECTRICAL

 Electrical Ratings: 115 / 60 / 1
 Line Voltage: 115 Volts - Single Phase
 Stepdown XFMR:

CONSTRUCTION

 AHU Cabinet Dimensions (Internal) Width (in): 32 Height (in): 34
 Burner Section Air Tunnel Dimensions: Width (in): 32 Height (in): 34
 Vestibule Dimensions: Length (in): 48 Height (in): 34

Vestibule Notes:

Vestibule/ Shroud Matl: 304SS Airside/Galv. Outside

GAS TRAIN COMPONENTS

ID	Part #	Qty
Modulator	PRV/FCV,PV/FCV,FCV,PR/FCV	MR212E-1212 1
Main Solenoid	SSV,CV	V4295A1056 2
Hydraulic Valve	SSV/ZSC	
Power Head	SSH/ZSC	
Vent Valve	VV-NO	
Pilot Regulator	PPRV	325-3-44-0076 1
Pilot Valve	PSSV	8214G020 1
Gas Safety Switch Low	PSL	C6097A1053 1
Gas Safety Switch High	PSH	C6097B1028 1
Main Gas Regulator	PRV	
Step Down Regulator:		

ELECTRONIC CONTROLS

 Designation: CA (customer provided modulating signal)
 Flame Safeguard: LME71.111A1PKG-PRG14 Qty: 1
 Base: _____ Qty: _____
 Timing (sec): _____ Card: _____
 Sense Type: Flame Rod Optional Remote Sensor: _____
 Sensor: _____ Qty: _____
 Ignition XFMR: Q624A1014/U Qty: 1
 24V XFMR: HM24VTRANS2 Qty: 1
 Auxiliary High Limit: HIGHLIMITKIT-DF-EXT

MODULATING CONTROLS

 Amplifier: SC11S-B
 Temp. Range: _____
 Temperature Sensor: _____
 Temperature Dial: _____
 Mixing Tube: _____
 Control Signal: 0-10 VDC

AIR SIDE PERFORMANCE

 Airflow Option: Constant
 Airflow (SCFM): 4,500 VAV Low Airflow: _____
 Velocity (FPM): 2,845 Inlet Temperature (oF): 0
 Pressure Drop ("wc): 0.68 Discharge Temperature (oF): 208

BURNER PERFORMANCE

 Fuel: Natural Site Press (psi): 0.5
 Burner Selection: Midco Design Press (psi): 2.0
 Max Capacity (Btuh): 1,098,783 Min Capacity(Btuh): 42,300
 Turndown: 26 Rate MBH/ft.: 549
 Gas Train Code: CSA B149
 Gas Train Size (in.): 1.5
 Manifold Pressure "wc High Fire: 4.19
*Manifold Press. is DIFFERENTIAL PRESS. Calculated at a 0"wc external static pressure
BURNER PROFILE PLATE

 Width (in): 22.00 Height (in): 19.49
 Profile Mtl: 18 Gauge Galvanized opening w/
 Damper Mtl: 18 Gauge Galvanized Damper: 17.49

BURNER CONSTRUCTION

 Setting ("wc): _____
 Setting ("wc): _____
WEIGHTS (lbs):

 Shipping Weight: 436 lbs.
 Installation Weight: 324 lbs.

Comments:

 DF Series Heat Modules are to be installed on the negative side of the circulating air blower.
 Complete wiring and piping included

 These Units carry an ETL or UL Recognized Component Listing to ANSI Z83.25
 Overpressure protection device to be supplied by others if required.

 CSA B149 - All tubing must use flared fittings

i) Direct Heater 2D Drawing

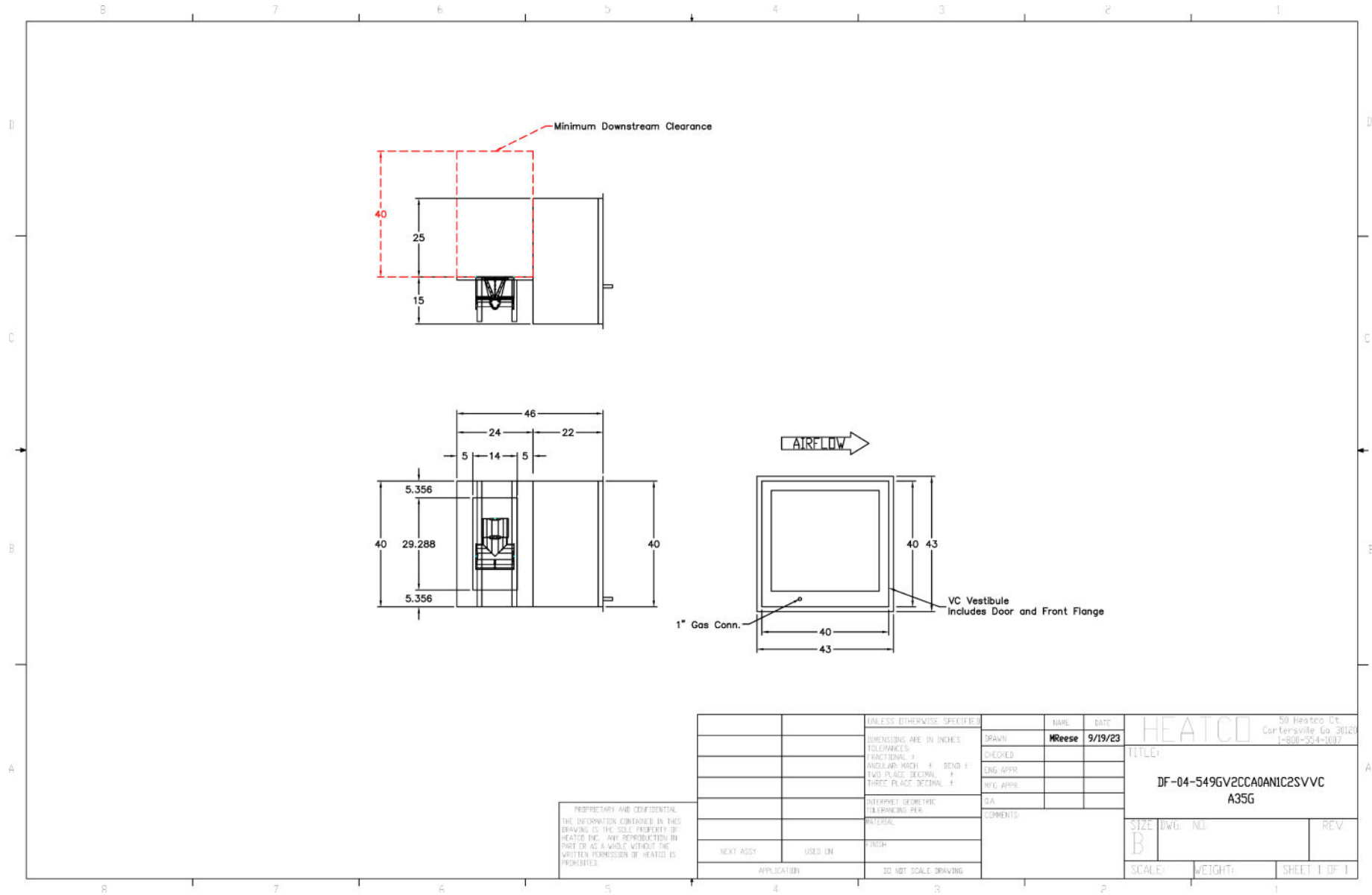

PROPRIETARY AND CONFIDENTIAL
 THE INFORMATION CONTAINED IN THIS DRAWING IS THE SOLE PROPERTY OF HEATED INC. ANY REPRODUCTION IN PART OR AS A WHOLE WITHOUT THE WRITTEN PERMISSION OF HEATED IS PROHIBITED.

		UNLESS OTHERWISE SPECIFIED:	NAME	DATE	
		DIMENSIONS ARE IN INCHES	DRAWN	HReese	9/19/23
		TOLERANCES:	CHECKED		
		FRACTIONAL: ±	ENG APPR		
		ANGULAR: MACH ± BEND ±	REL APPR		
		TWO PLACE DECIMAL: ±	QA		
		THREE PLACE DECIMAL: ±	COMMENTS:		
		INTERPRET GEOMETRIC TOLERANCING PER:			
		MATERIAL:			
		FINISH:			
NEXT ASSY	USED ON				
APPLICATION		DO NOT SCALE DRAWING			

HEATED		50 Heated Ct Cartersville Ga 30120 1-800-354-1007
TITLE:		
DF-04-549GV2CCA0ANIC2SVVC A35G		
SIZE	DWG NO	REV
B		
SCALE:	WEIGHT:	SHEET 1 OF 1

j) ALC Microprocessor Controller Data Sheet

OPTICORE LS-1628u Large Application Controller

The OEMCtrl® OptiCORE™ LS-1628u is a high-performance, BACnet native direct digital controller (DDC). It provides the speed, power, memory, and I/O flexibility needed for the most demanding control applications in the industry. Capable of controlling HVAC equipment with high I/O point counts including 44 points on the base controller and up to 224 through expandable I/O boards. Made with integration in mind, the LS-1628u can integrate with building automation systems via BACnet (IP or MSTP) or Modbus (IP or serial). It also allows for connecting to communicating devices like VFDs via BACnet or Modbus.

Key Features and Benefits

Performance / Hardware

- Powered by 32-bit ARM Cortex-A8, 600MHz, processor with multi-level cache memory with 16 GBs eMMC Flash memory and 512 MB DDR3 DRAM
- Flexible, color-coded and easy to wire I/O

Communication Features:

- 3 - Configurable Communication Ports
 1. Gig-E: 10/100/1000 Base T Ethernet Port for BACnet or Modbus communication, includes DHCP addressing
 2. Port S1: Rotary configurable EIA-485 Port for BACnet MS/TP or Modbus (primarily for BAS connection)
 3. Port S2: Firmware configurable EIA-485 Port for BACnet MS/TP or Modbus (primarily for communicating device connection)
- 6 - Dedicated Communication Ports
 1. Service Port: 10/100 Base T Ethernet port for technician access or for high-speed touchscreen connection
 2. Rnet: Sensor Network or for touchscreen connection
 3. I/O Bus Port: for I/O point expansion via screw terminal for remote mounting
 4. I/O Bus Edge Connector: for I/O point expansion (includes power)
 5. Act Net: Network of communicating valves and actuator
 6. Comm Expansion Edge Connector Port: for comm expansion

Servicability:

- Fully programmable using our powerful EIKON® graphical programming tool. Control sequences can also be fully simulated off-line within EIKON or on-line via "Live Logic" for real-time troubleshooting of the control logic while the equipment is running.
- Built-in support for the OEMCtrl Z5 intelligent communicating sensors and touchscreen display units including the Equipment Touch 4.3" touchscreen, and the OptiCORE EQT3s, the rugged, Android, panel-mount interfaces which come in 4.3", 7", & 10" sizes.

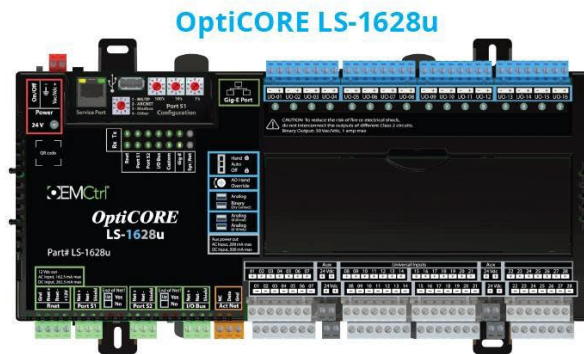

ASHRAE **BACnet**
Modbus

Support for EQT3 touchscreens



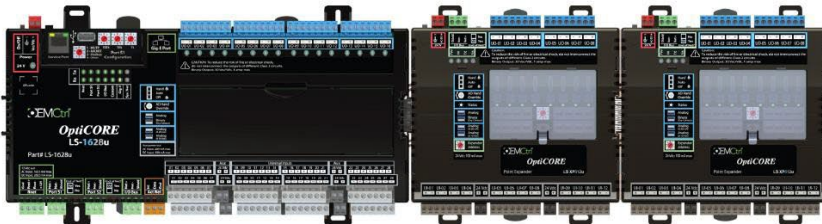

EQT3-7

Support for up to **9** I/O expanders (224 total points)



OEMCtrl®

Specifications

Power	24 Vac \pm 15%, 50-60 Hz, 100 VA, 24 Vdc \pm 10%, 48 W, Single Class 2 source only, 100 VA or less
Operating Range	-40° to 158° F (-40° to 70° C); 10 to 95% relative humidity, non-condensing
Universal Inputs (28) (Software selectable)	28 channels electronically configured to any of the following input types: Digital - Dry Contact OR Pulse Counting inputs up to 60Hz Analog - Voltage (0-5 or 0-10 Vdc) OR Current (0-20 mA) OR Thermistor (Precon Type II 10k Ω OR Carrier YSI 5k Ω OR S-5700-850 10k Ω w/ 11k Ω shunt) OR RTD (Platinum RTD TS-8000 1k Ω @ 32°F (0.00385 TCR) OR Platinum RTD 1k Ω @ 32°F (0.00375 TCR) OR Nickel-iron RTD 1k Ω @ 70°F, 699 Ω @ -40°F OR Balco (Nickel-iron) TS8000 RTD 1k Ω @ 70°F, 779 Ω @ -40°F. 16 bit A/D resolution 24VDC auxiliary sensor power(8): 200mA max. (AC power input) 500 mA max. (DC power input)
Universal Outputs (16) (Hardware selectable)	16 channels configurable to any of the following output types: Voltage (0-10 Vdc) OR Current (0-20 mA) OR Relay contacts, potential free, normally open, rated 24VAC/DC @ 1 Amp (resistive) Hand/Auto/Off override switches for all outputs. Potentiometer for manual adjustment of all analog outputs. Status LED for all outputs. 12 bits D/A Resolution (AOs)
Communication Ports BACnet Modbus	 Gig-E port: 10/100/1000 BaseT Ethernet port for BACnet/IP and/or BACnet/Ethernet and/or MODBUS TCP/IP communication on the Ethernet at 10, 100, or 1000 Mbps, full duplex Port S1: High-speed EIA-485 port with End of Net switch configurable with rotary switch: <ul style="list-style-type: none"> • BACnet MS/TP network at 9.6, 19.2, 38.4, 57.6, 76.8, or 115.2 kbps • Modbus RTU network at 9.6, 19.2, 38.4, 57.6, 76.8, or 115.2 kbps Port S2: Electrically isolated EIA-485 port with End of Net switch configurable in firmware: <ul style="list-style-type: none"> • BACnet MS/TP or Modbus RTU network at 9.6, 19.2, 38.4, 57.6, 76.8, or 115.2 kbps Service port: 10/100 Base T Ethernet port for technician use and local EQT displays Rnet port: Communicate with ZS communicating sensors and local EQT displays USB port: USB 2.0 host port for device recovery
Real Time Clock	Real-time clock keeps track of time in the event of a power failure for up to 3 days
Protection	Two fast acting, 5mm x 20mm glass fuses: <ul style="list-style-type: none"> • A 2A fuse for the LS-1628u's power / A 4A fuse for the I/O bus edge connector The power and network ports comply with the EMC requirements EN50491-5-2.
Microprocessor / Memory	32-bit ARM Cortex-A8, 600MHz, processor with multi-level cache memory / 16 GBs eMMC Flash memory and 512 MB DDR3 DRAM
Compliance/Listing  	BACnet: Conforms to the BACnet Building Controller (B-BC) Standard Device and BACnet BBMD (B-BBMD) Device as defined in BACnet 135-2001 2012 Annex L and tested to Protocol Revision 14. United States: FCC compliant to Title CFR47, Part 15, Subpart B, Class A; UL Listed, File E143900; CCN PAZX, UL 916, Energy Management Equipment; ANZ: RCM Mark AS/NZS 61000-6-3; Canada: UL Listed File E143900, CCN PAZX7, CAN/CSA C22.2 No. 205 Signal Equip., Industry Canada Compliant ICES-003, Class A; CE Mark Compliant with 2014/30/EU, and RoHS Compliant: 2015/863/EU; UKCA Mark compliant with Electromagnetic Compatibility Regulations 2016 – Gov.UK and RoHS for Electrical and Electronic Equipment 2012.

Physical	Supports up to 9 OptiCORE I/O expanders	Dimensions Overall A: 12.75 in. (32.38 cm) B: 6.95 in. (17.68 cm) Depth: 2.09 in. (5.31 cm) Weight: 2.7 lb. (1.22 kg)
	OptiCORE I/O expanders <ul style="list-style-type: none"> • LS-XP812u • LS-XP48u • LS-XP012u DIN rail or Screw mounting Minimum panel depth: 2.75 in. (7 cm)	

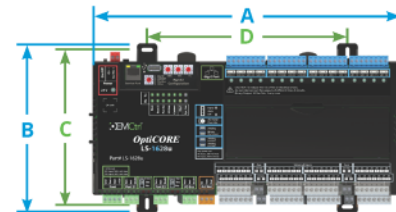

Fire-retardant plastic ABS, UL94-5VA

All trademarks and service marks referred herein are the property of their respective owners.

A Carrier Company
©2021 Carrier. All Rights Reserved.

Rev 10/2022

oemCtrl

1025 Cobb Place Boulevard, Kennesaw, GA 30144
770-429-3060 | oemctrl.com

Manuals are given in web links instead of screenshot, due to the volume of pages.

k) Direct Fired Heater Modules Link

Heatco OEM Installation Instructions

<https://www.heatco.com/download/DF-OEM-MAN-LIST-Z83-25.pdf>